

Medium Voltage Contactless Power Transfer for Data Center Application

Isaac Wong

North Carolina State University

Presented at PSMA on Wednesday March 19, 2025



Current Data Center Power Distribution Architecture

- 480 Vac Distribution
- Multiple stages of conversion
- 4160Vac -> 480Vac -> 415/240Vac -> 208Vac
- Drawbacks
 - Power loss at each conversion stage
 - Low voltage transmission, large size copper cable

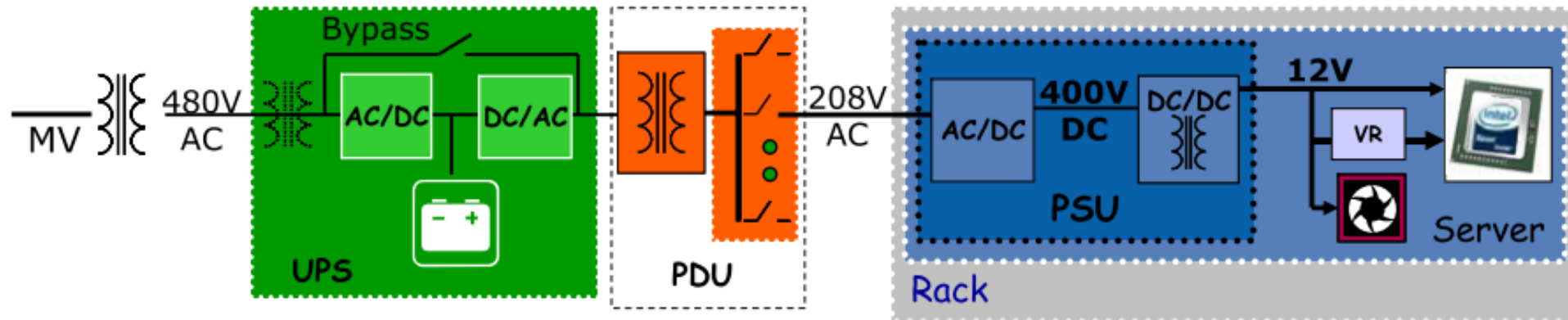

480Vac Distribution

DC Distribution and Cable Size

- Higher the distribution voltage
- Lower the current drawn

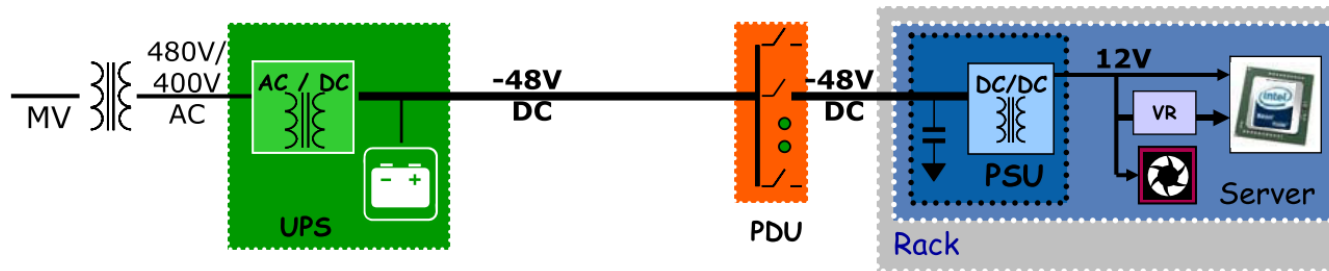

48Vdc Distribution

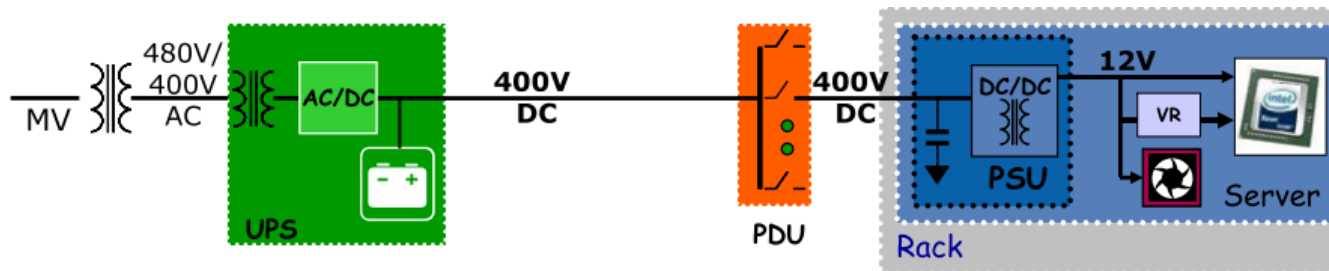

400Vdc Distribution



	48 Vdc	400 Vdc
No of Cables	20	2
Copper Area per Cable [mm ²]	325	200
Total Copper Area [mm ²]	6500	400

16 times copper surface area reduction for 400Vdc vs 48Vdc

MVDC Distribution

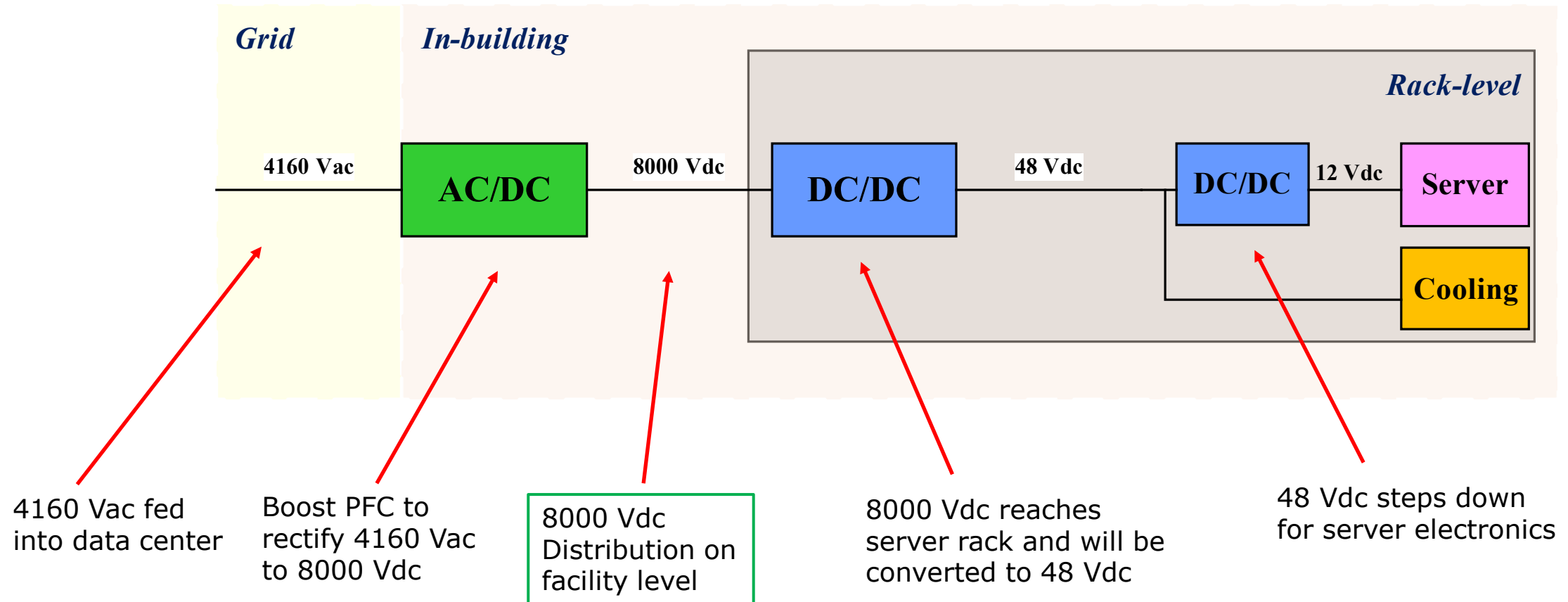

MVDC Distribution Challenges

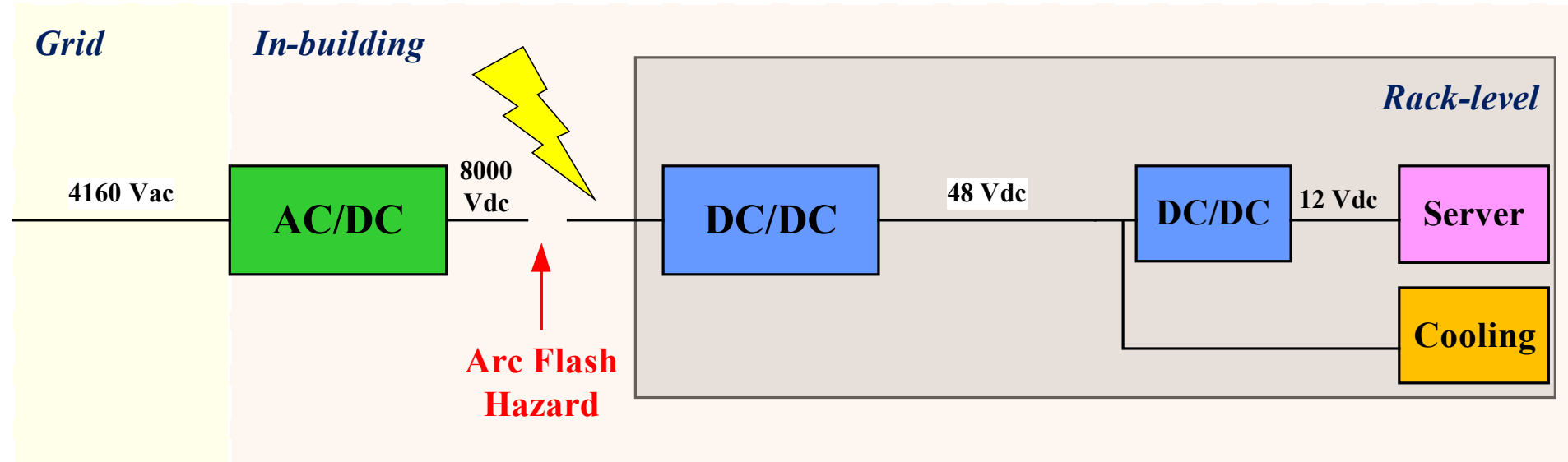

- Arc Flash Hazard
- 8000 Vdc needed to be disconnected when server units need maintenance
- Arc flash is likely to occur due to high voltage difference
- Not economical to have MVDC switchgears at every server rack
- Require arc flash mitigation at the power supply level

Solution - Contactless Power Transfer

- Power transfer via inductive coupling
- Split-core transformer as a magnetic plug
- No ohmic contact of conductors
- No high dv/dt
- Arc-flash mitigated

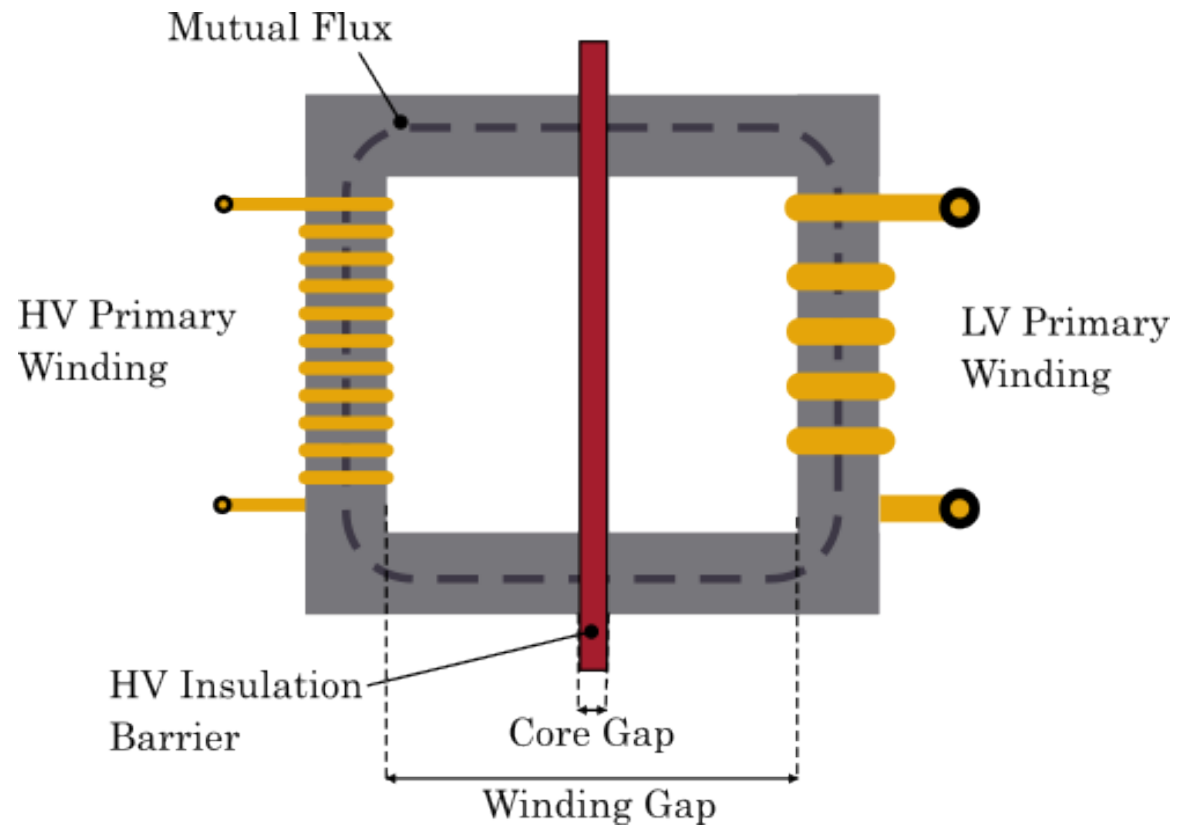

Effect of Core Gap and Winding Gap

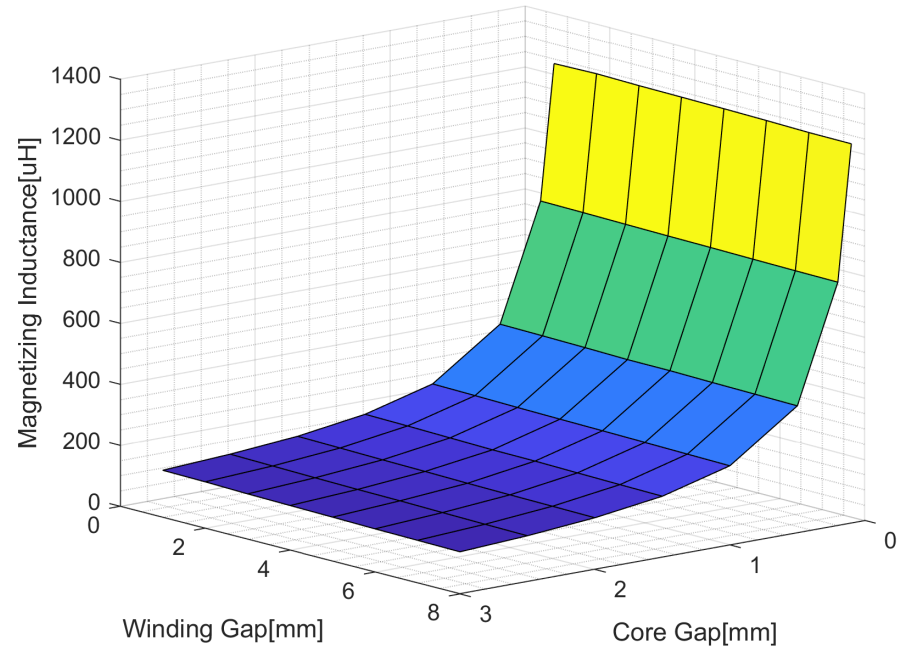

- Magnetizing inductance decreases exponentially with core gap
- Low magnetizing inductance

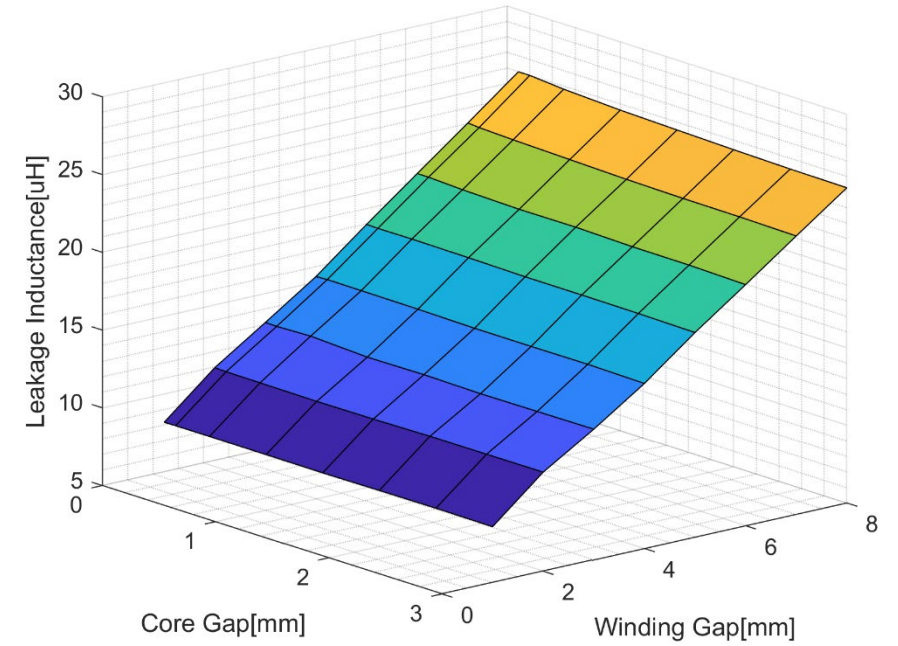

- Leakage inductance increases linearly with winding gap



Resonant Topology - LLC

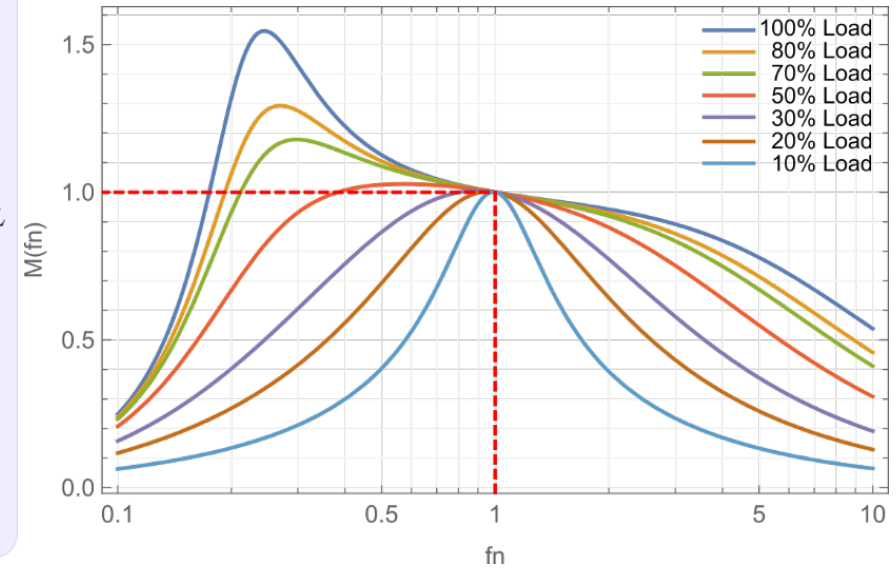
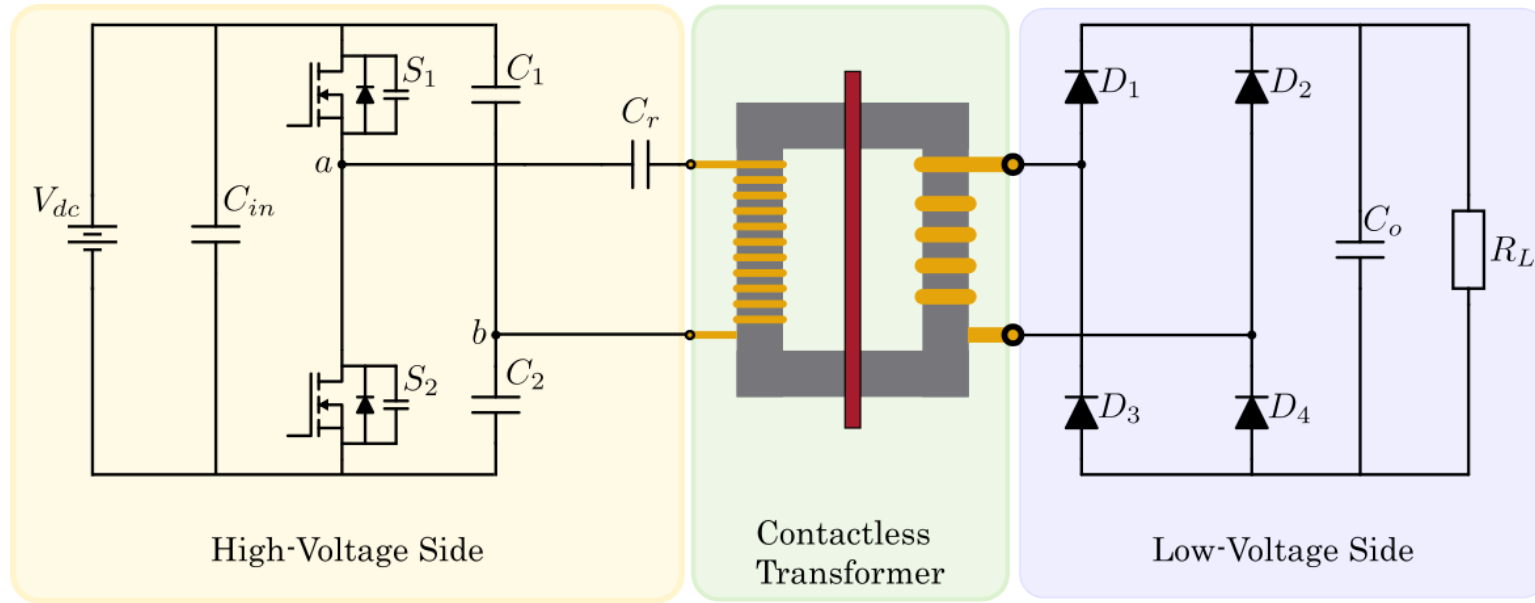

- LLC is used to compensate high leakage and low magnetizing
- Unity gain at resonance point
- DC-transformer operation
- HV half-bridge offer a gain of 0.5
- Lower transformer voltage stress, i.e. $0.5V_{dc}$

1000V/ 20kW MVDC Contactless Power Supply

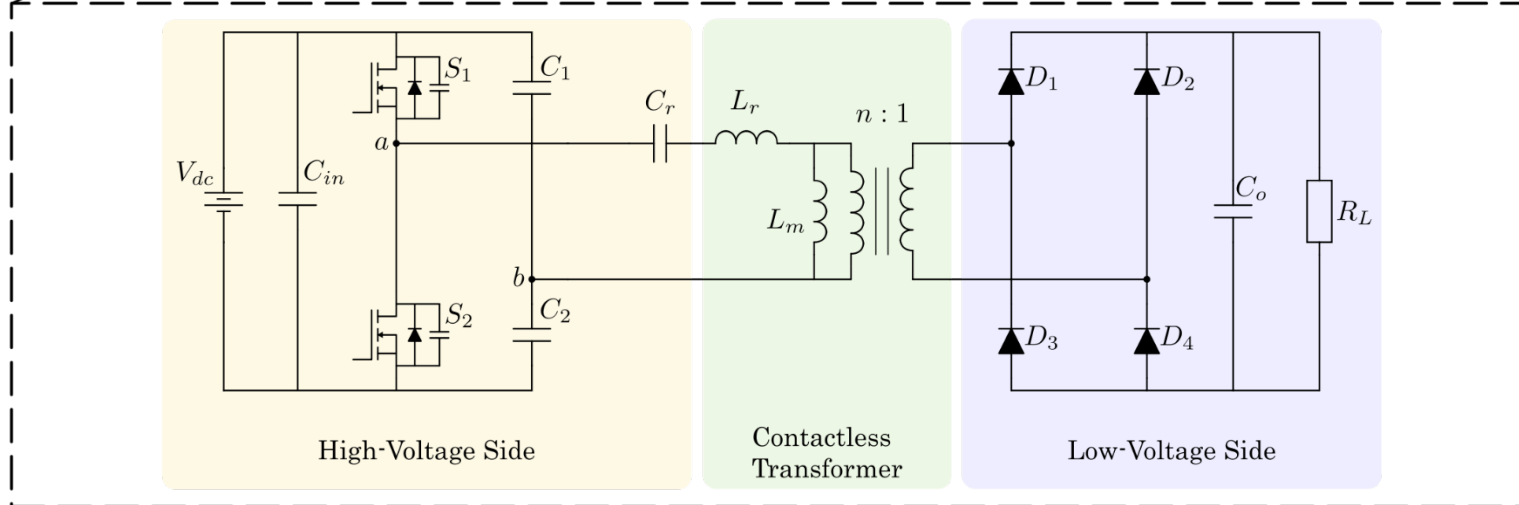
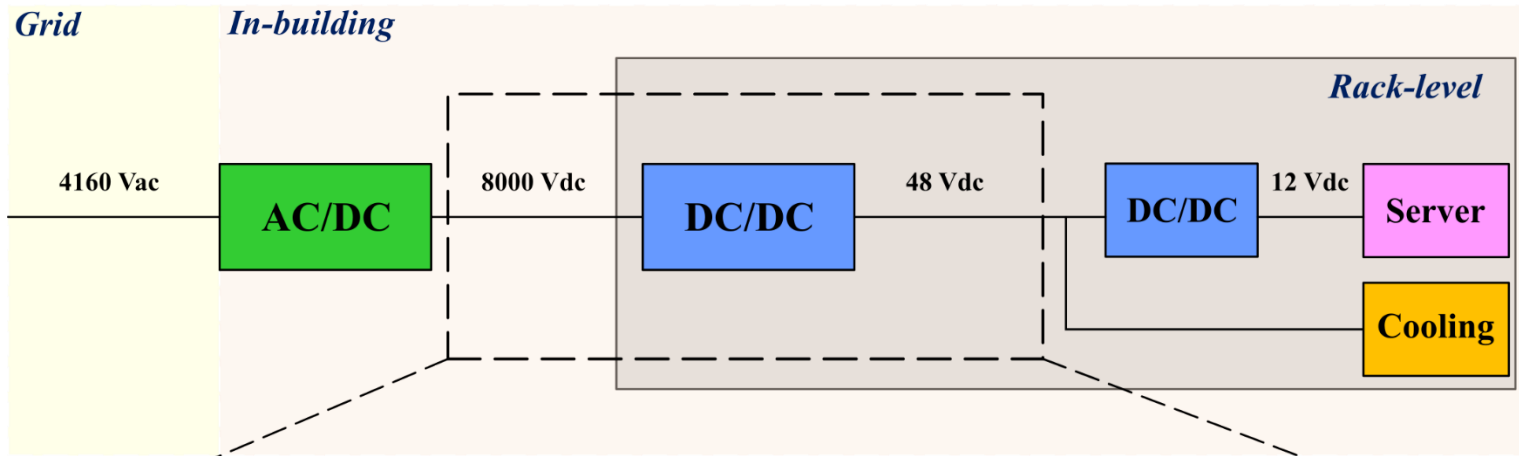

Specification	Value
Nominal Input Voltage	1000V
Nominal Output Voltage	48V
Nominal Output Current	400A
Rated Power	20kW
Efficiency Target	95% @ 50% Load 91% 100% Load 90% @ 20% Load

- 1000V chosen for validation phase
- Opens the pathway to 2000V, 4000V, 8000V

Transformer Design Procedures

1.) Area Product Method to determine dimension of transformer

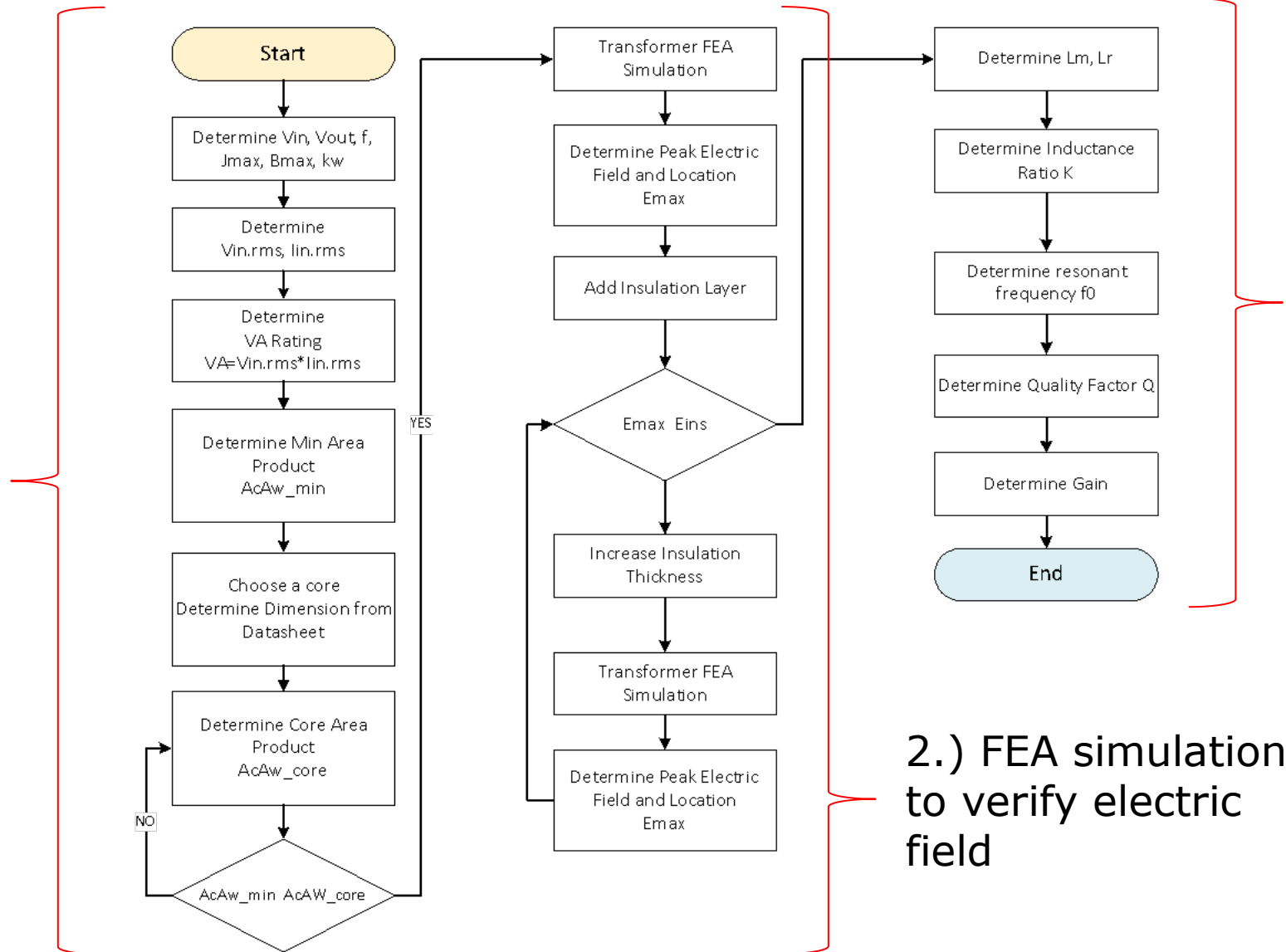

3.) Use leakage & magnetizing to determine LLC resonant tank

2.) FEA simulation to verify electric field



20kVA Contactless Transformer Design Overview

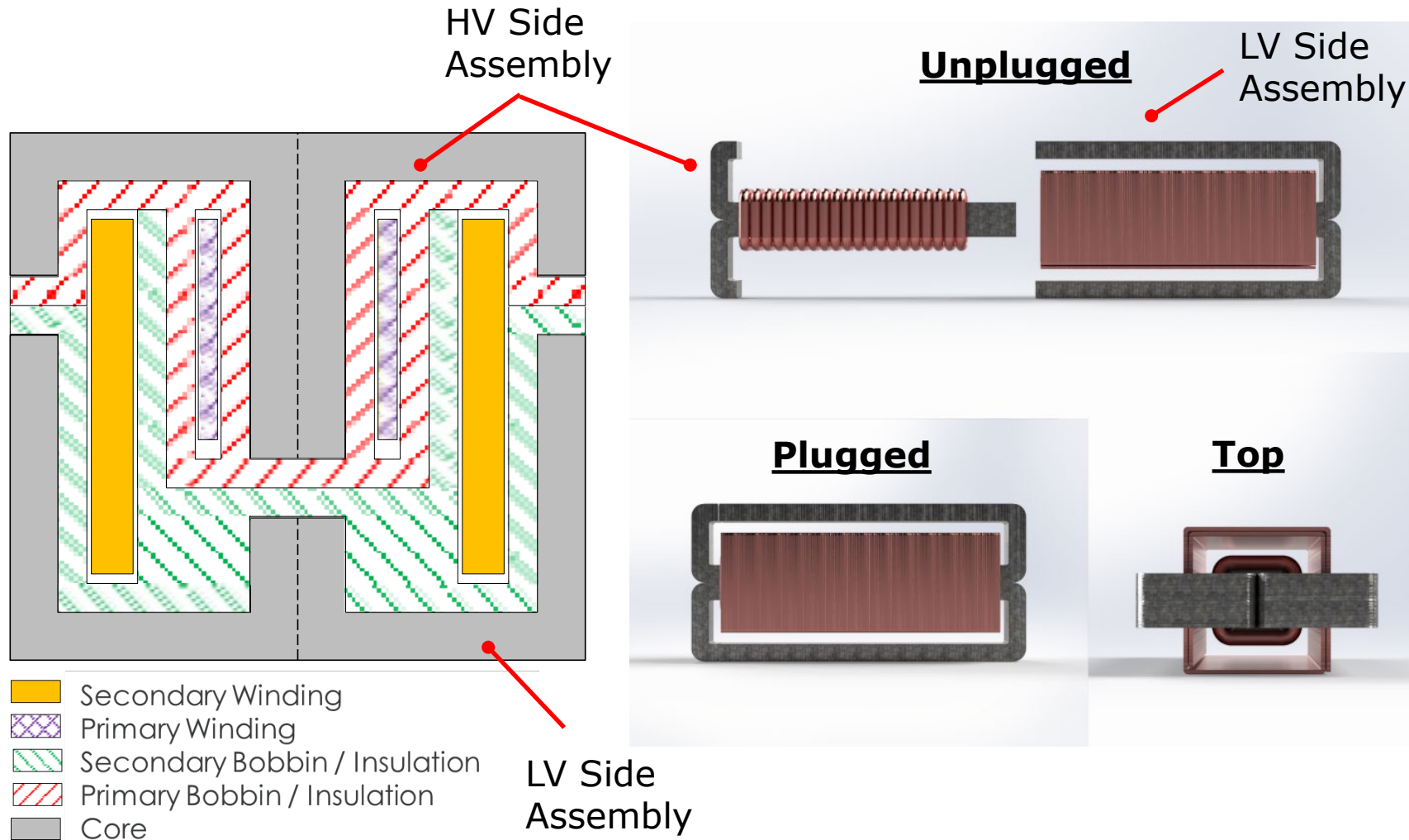

Specification	Value
Core Material	Nanocrystalline
Primary side	500V/ 20A
Secondary side	50V/ 400A
Turns-ratio	20:2
Primary Winding	Litz Wire
Secondary Winding	Copper Foil
Lm	346 μ H
Lr	27 μ H
Core Gap	0.5mm
Winding Gap	8 mm



Experimental Testing

- ZVS operation at
- 2kW (10% load)
- 20kW (100% load)

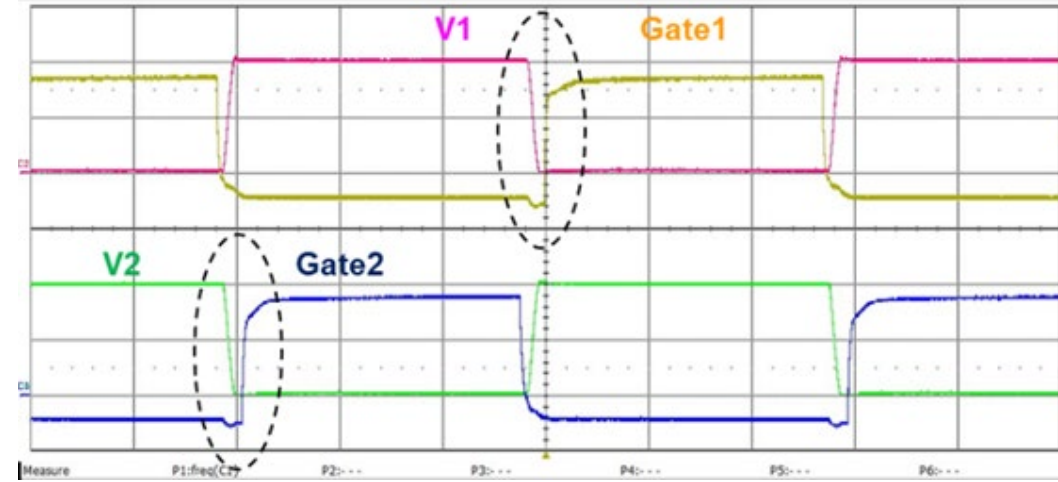
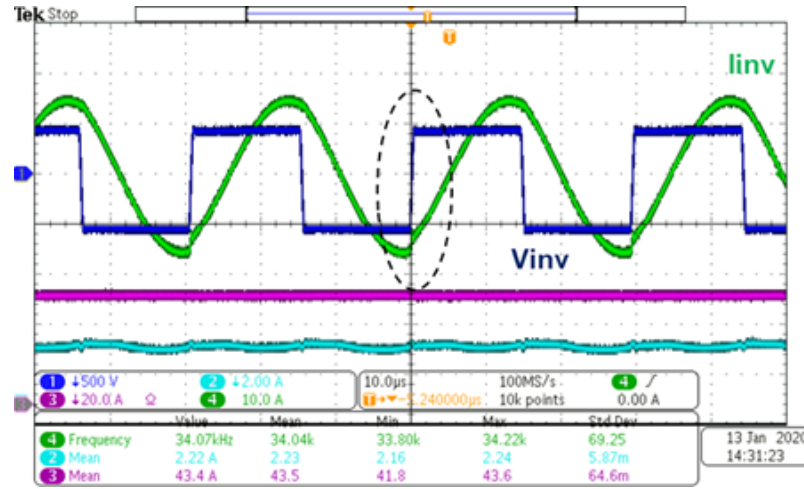

1000V, 2kW

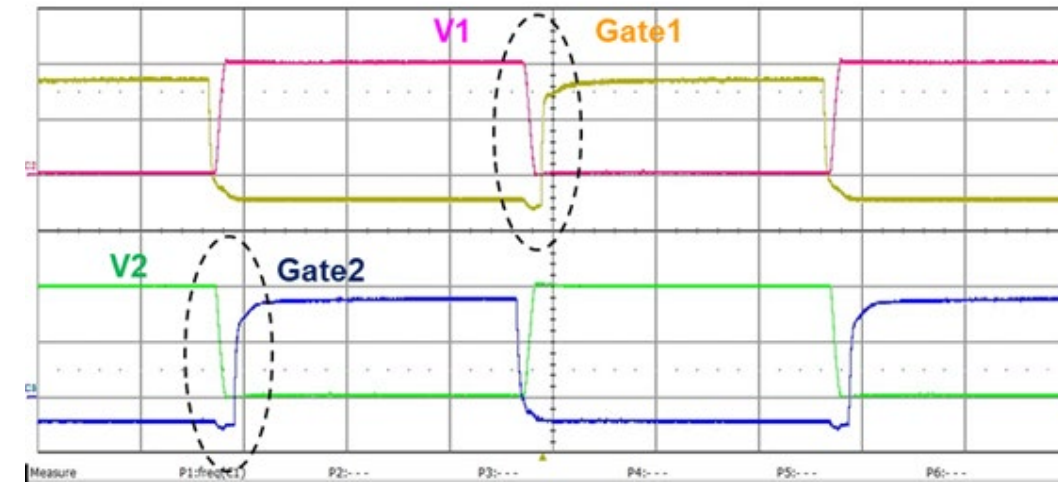
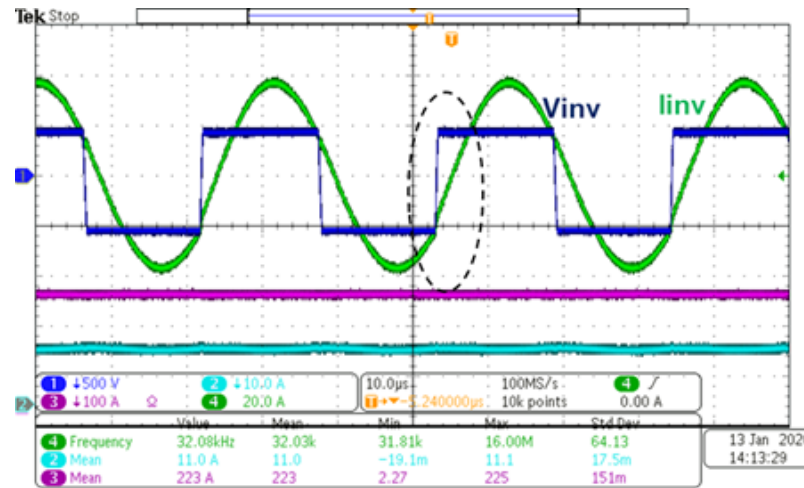

1000V, 20kW

ZVS Operation across load range



Experimental Efficiency

- Transformer efficiency peaked at 6kW
- 97% efficient at full power 20kW
- High current (>400A) leads to high conduction loss at high power
- Secondary transformer winding can be further improved with parallel conductors

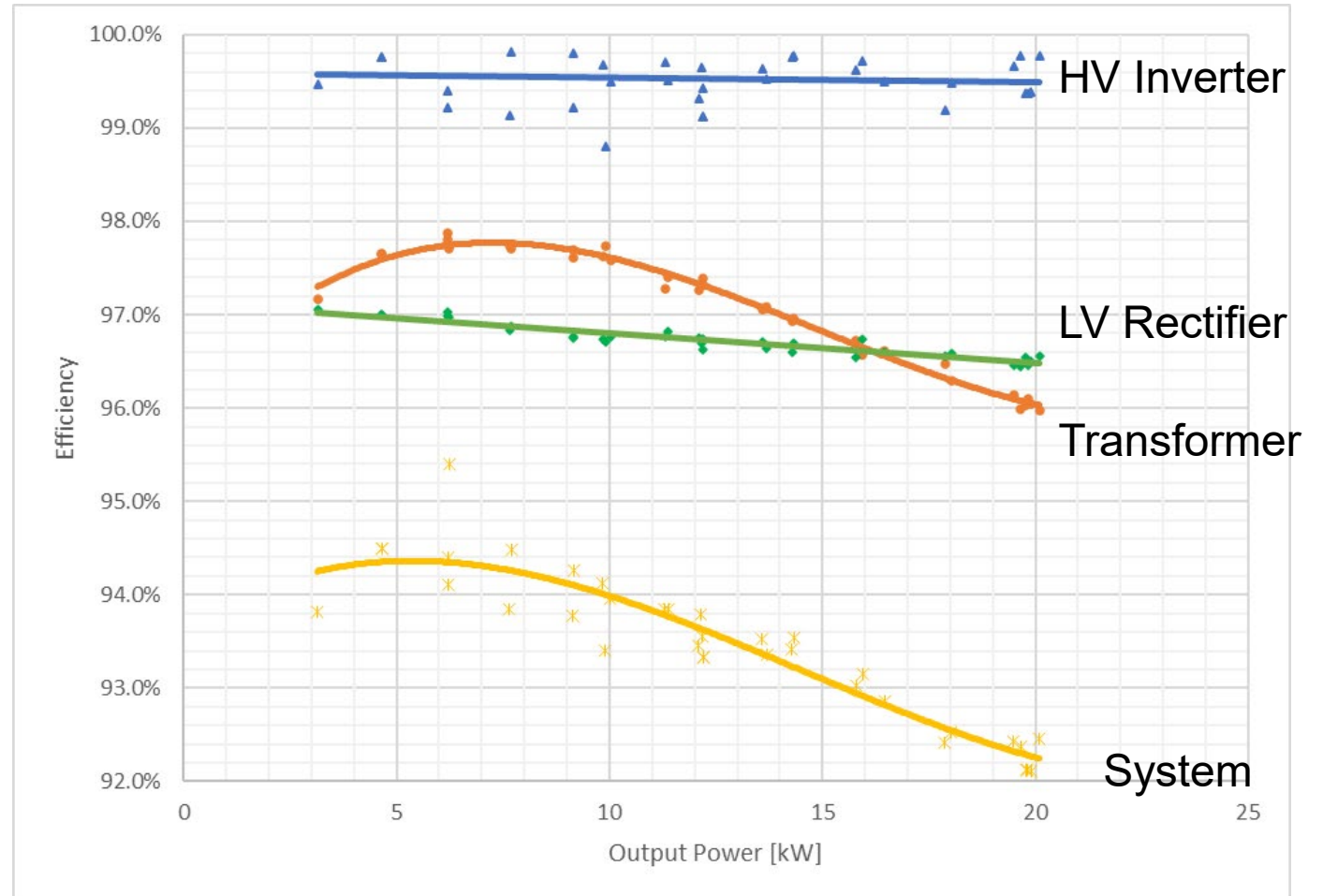

Experimental Efficiency

- Experimental results to compare SR and diode rectification
- SR improves efficiency by
- 2.3% average
- 3.8% highest at 3kW
- Peak efficiency: 95.7%
- Full load efficiency: 93.7%

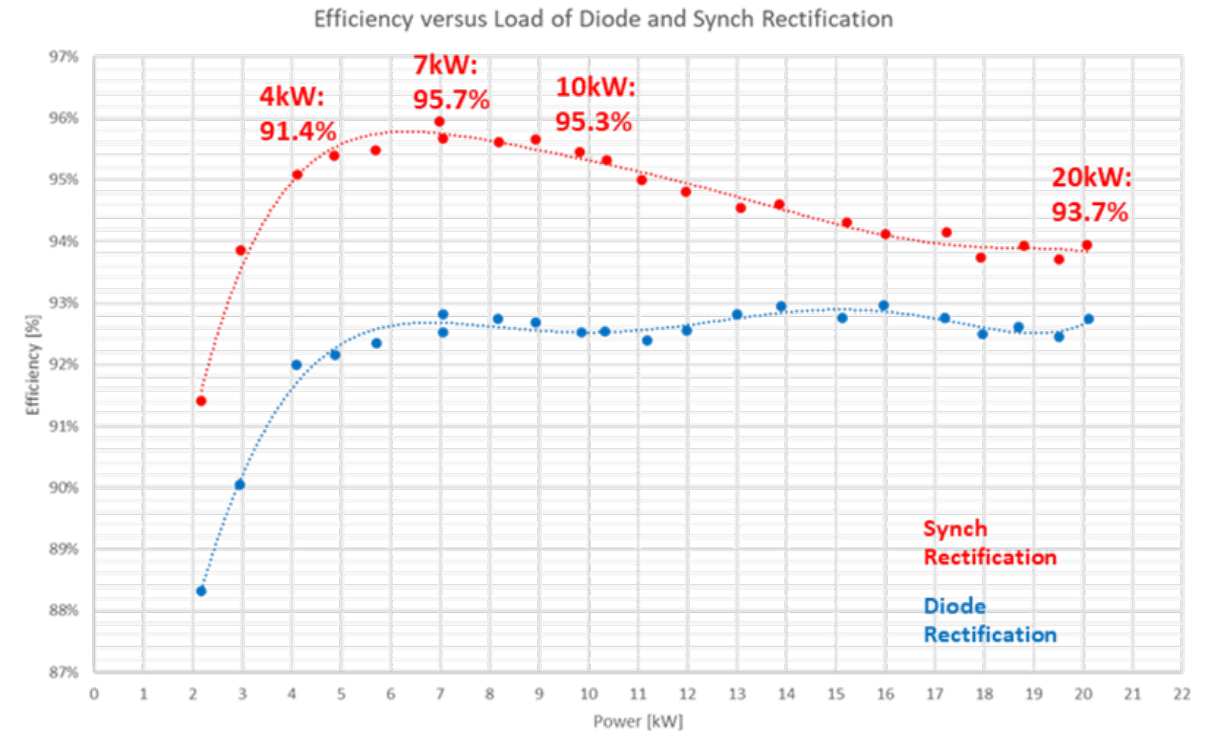

Conclusion and Future Work

- Contactless power transfer is proposed as a solution to provide MV to data center server racks
- Experimental prototype demonstrated at 1000V and 20kW
- Further studies on circuit and transformer topologies are on-going



Thank you for your interest.

Isaac Wong

North Carolina State University

Email: twong3@ncsu.edu

Session: The Transformer in the Solid-State Transformer

