

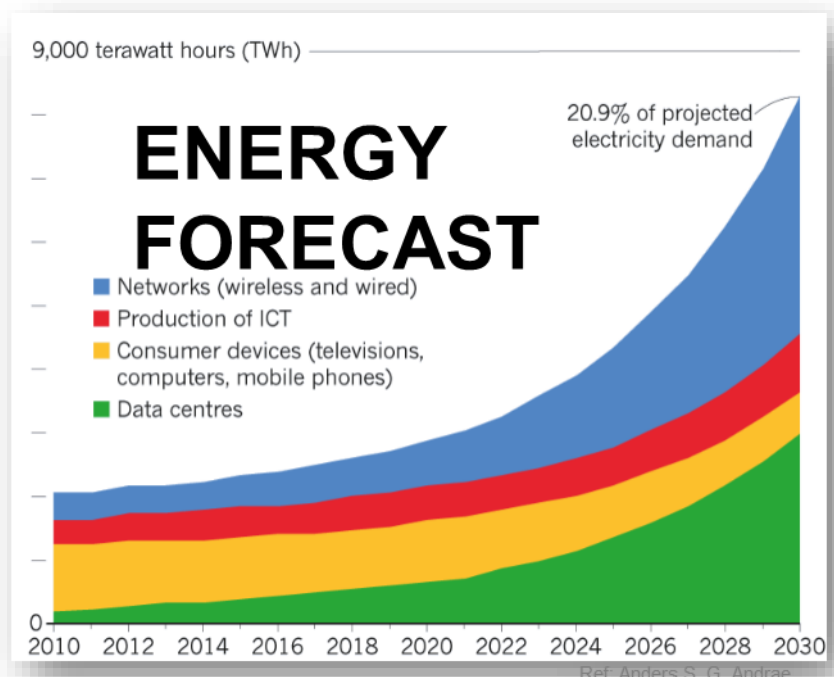

a YAGEO company

MLCCs for New Power Conversion Solutions

Connect & Engage



POWER DENSITY POWER EFFICIENCY

Watts/cm³ miniaturization
lower losses less cooling

**WIDE
BANDGAP
(SiC, GaN)**

300KHz - MHz

HIGH

Up to 200°C

HIGH

FREQUENCY

VOLTAGE

TEMPERATURE

CURRENT

10KHz - MHz

LOW to HIGH

Up to 125°C

VERY HIGH

**RESONANT
TOPOLOGY
(LLC)**

AGENDA & SPEAKER

Agenda

1. Challenges in power conversion
2. Solutions from the passive space
3. Applications in-circuit

About the Speaker



Wilmer Companioni, Senior Technical Marketing Manager
BSEE University of Florida
15 years of industry experience
2 years in sales
7 years in marketing
10 years in engineering design

POWER CONVERSION CHALLENGES

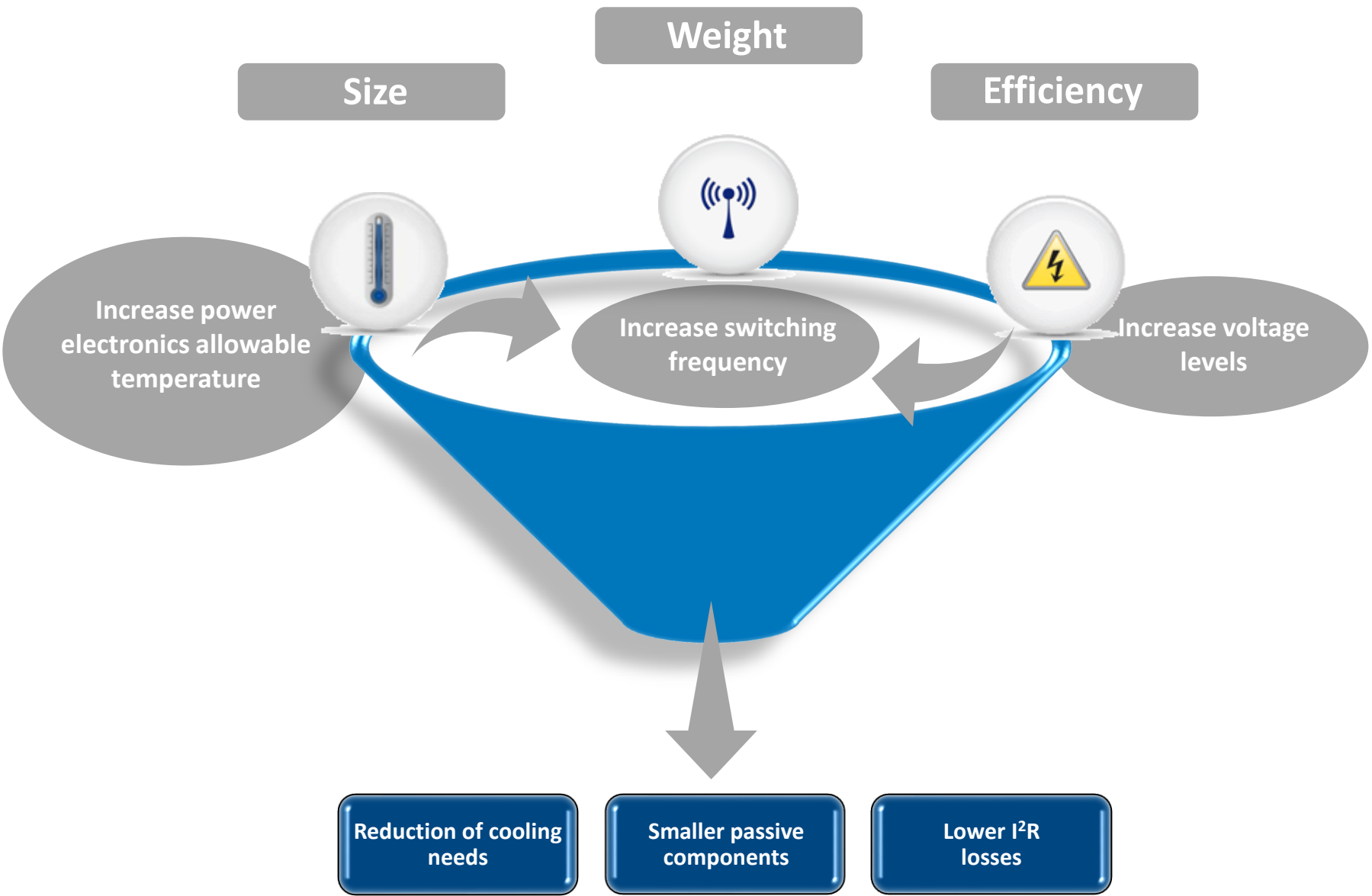

Snubber

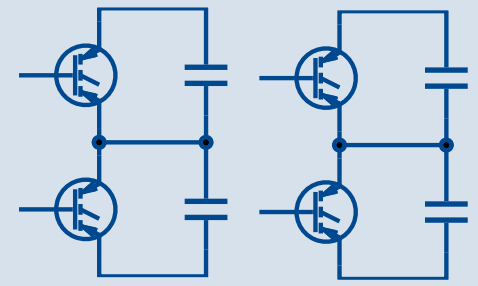

DC Link

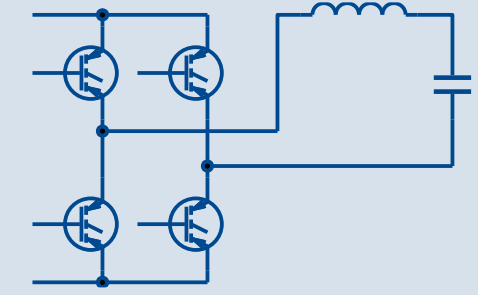

Resonant

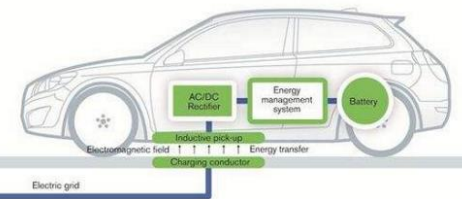
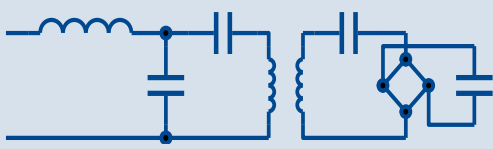

THE SEMICONDUCTOR RESPONSE

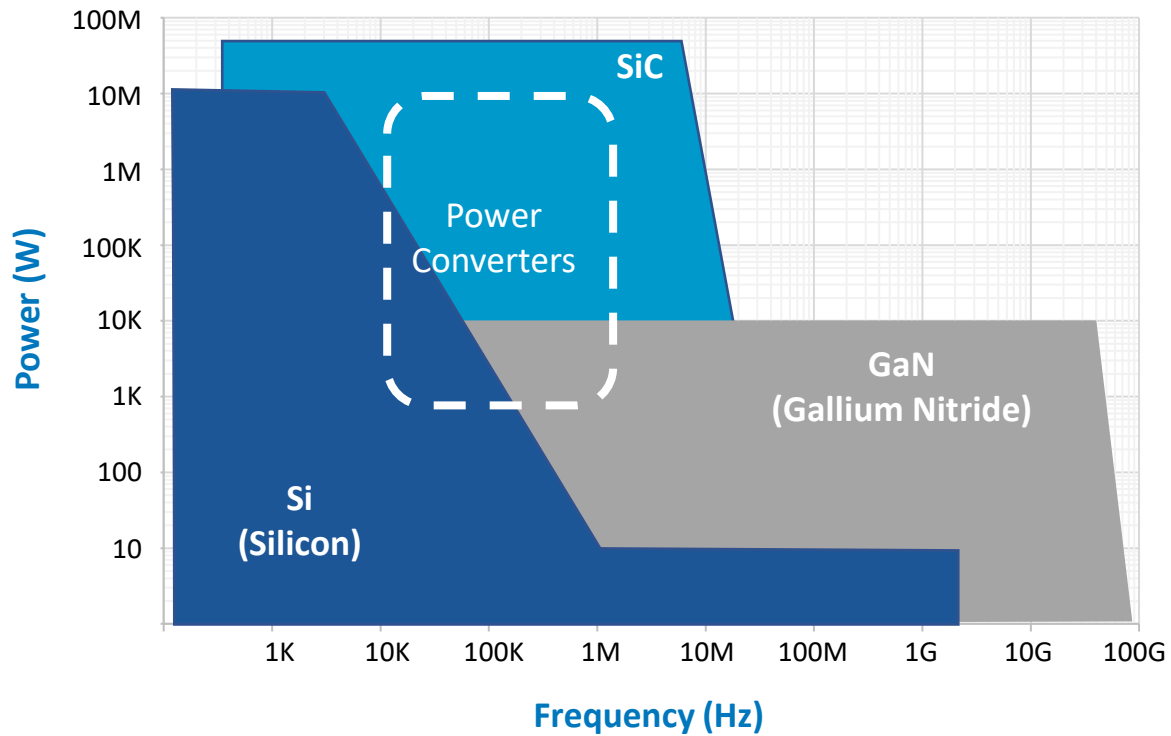

Semiconductor Material	Bandgap Energy (eV)
Germanium (Ge)	0.7
Silicon (Si)	1.1
Silicon Carbide (SiC)	3.3
Gallium Nitride (GaN)	3.4

Wide Bandgap

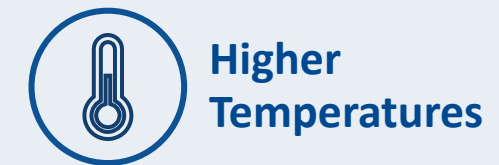

THE IMPACT ON CAPACITORS



>1700V

Reliable performance at higher voltages

>1MHz

Smaller, low ESR, low ESL low loss capacitors with high current handling capability

>150C

Reliable performance at elevated temperatures $\geq 125^{\circ}\text{C}$ with robust mechanical performance
Packaging close to the hot semiconductor to:

- Lower ESL
- Minimize cooling costs

THE SOLUTION: ULTRA-STABLE COG

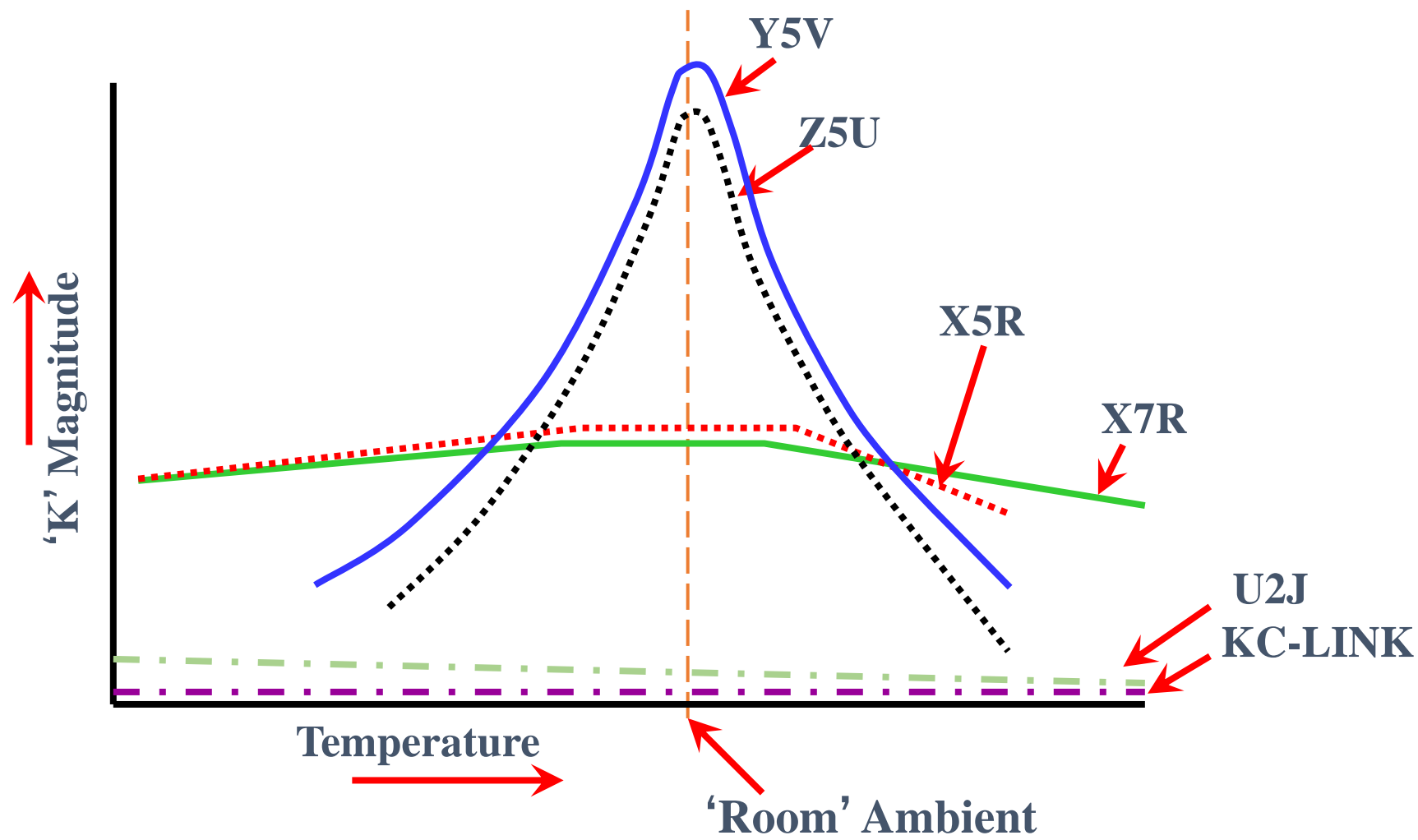

Stability Across



Voltage



Frequency



Temperature

PERFORMANCE CHARACTERISTICS

Capacitance Stability

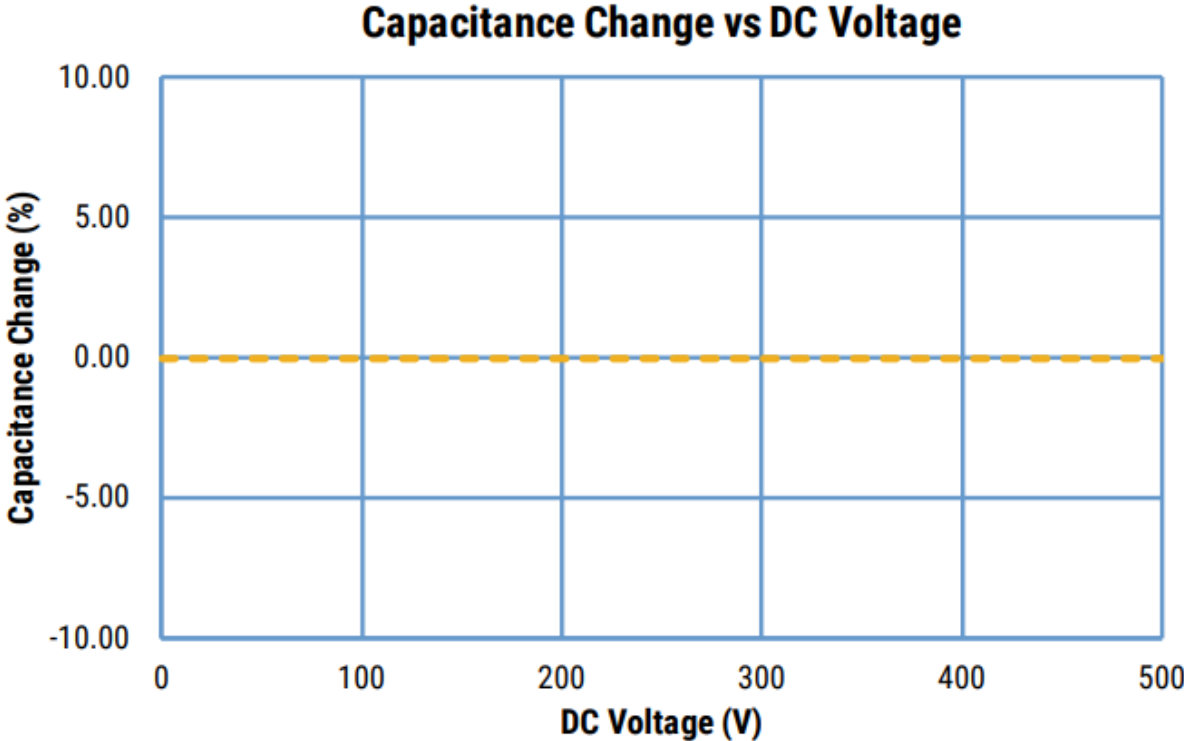
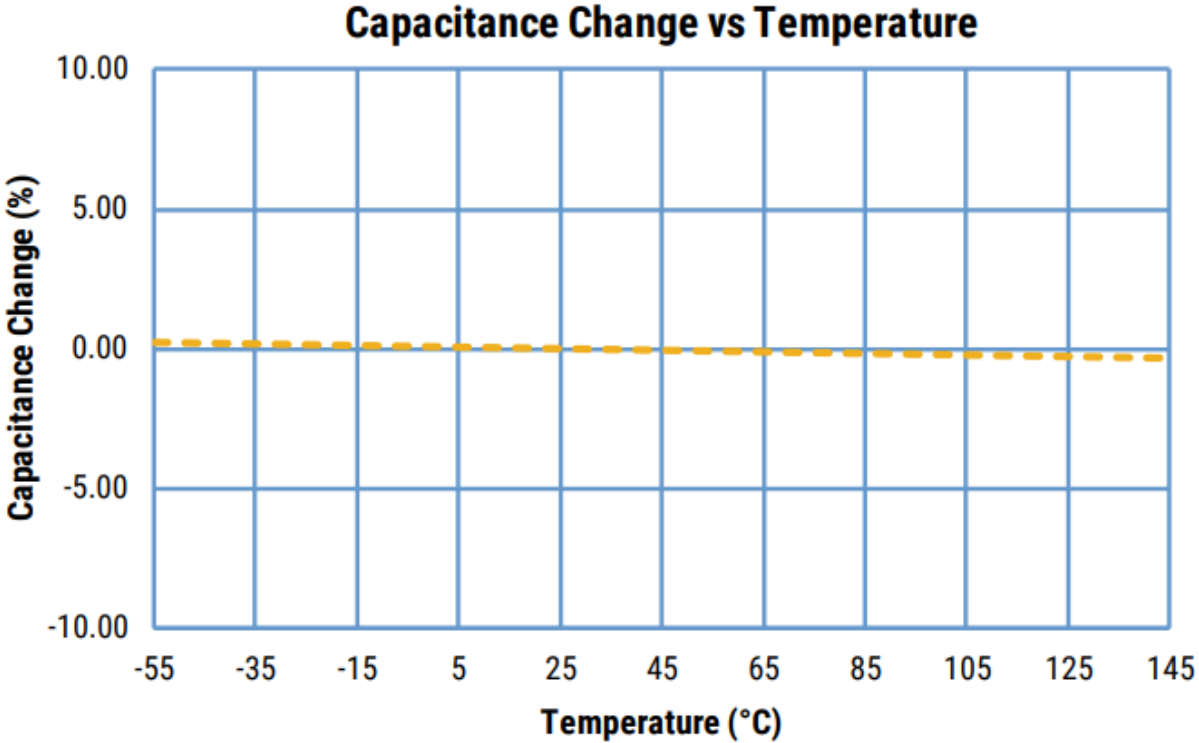

PERFORMANCE CHARACTERISTICS

Ripple Performance

Typical AC Current Performance, EIA 1812 (CKC18)

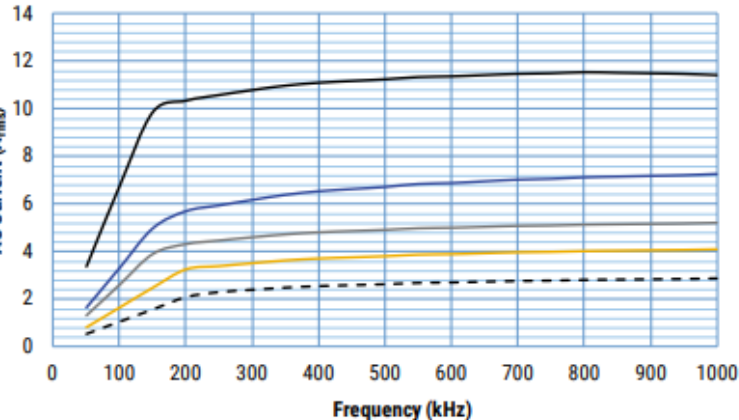

- 4.7nF 1000V
- 7.5nF 1000V
- 15nF 1000V
- 18nF 650V
- 47nF 650V

Typical AC Current Performance, EIA 2220 (CKC21)

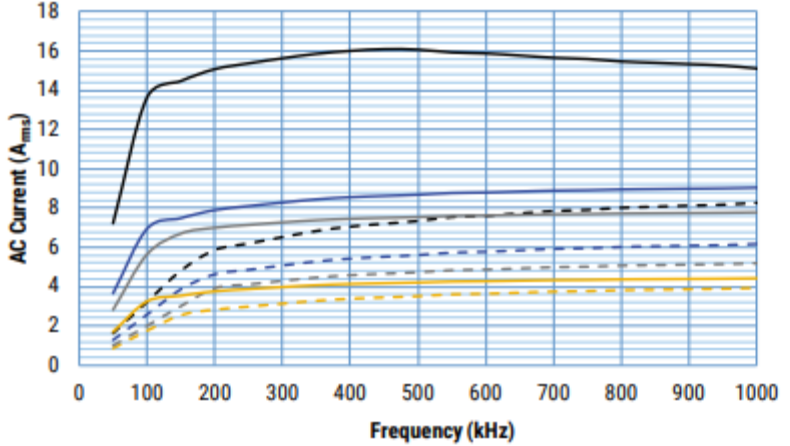

- 4.7 nF 1,700 V
- 6.8 nF 1,700 V
- 7.5 nF 1,200 V
- 12 nF 1,200 V
- 15nF 1,000 V
- 33 nF 1,000 V
- 39 nF 650 V
- 100 nF 650 V

Typical AC Current Performance, EIA 3640 (CKC33)

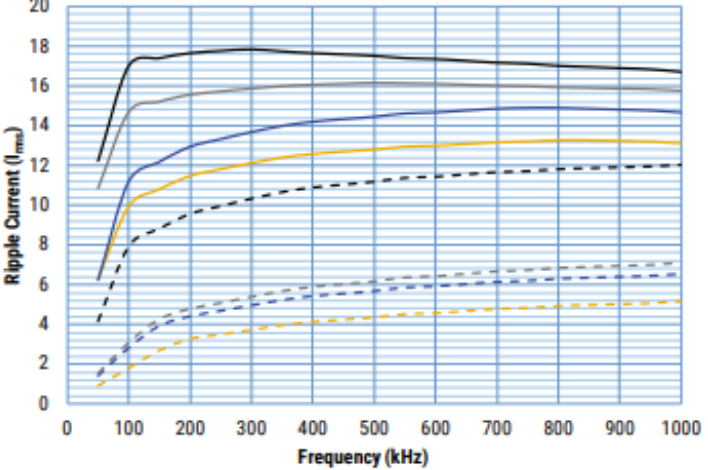

- 4.7nF 1700V
- 7.5nF 1700V
- 8.2nF 1700V
- 22nF 1700V
- 47nF 1200V
- 56nF 1000V
- 150nF 650V
- 220nF 500V

Typical AC Voltage Performance, EIA 1812 (CKC18)

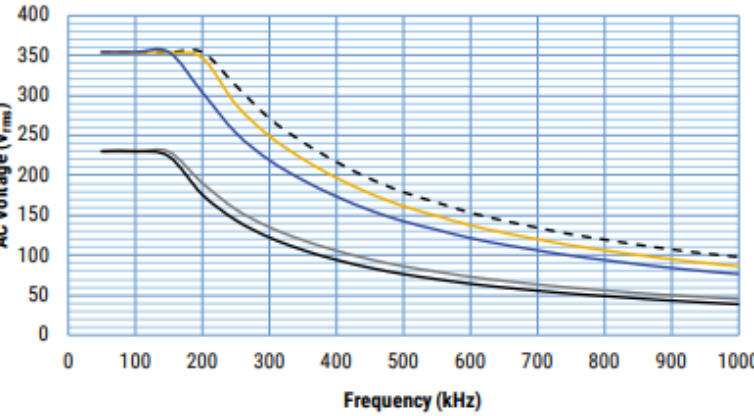

- 4.7nF 1000V
- 7.5nF 1000V
- 15nF 1000V
- 18nF 650V
- 47nF 650V

Typical AC Voltage Performance, EIA 2220 (CKC21)

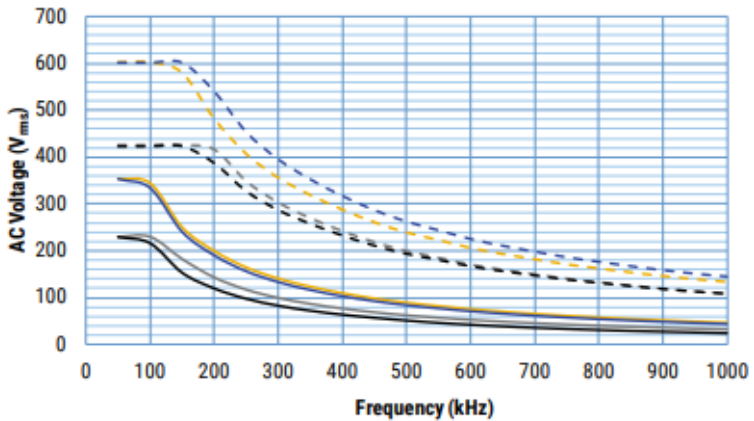

- 4.7 nF 1,700 V
- 6.8 nF 1,700 V
- 7.5 nF 1,200 V
- 12 nF 1,200 V
- 15nF 1,000 V
- 33 nF 1,000 V
- 39 nF 650 V
- 100 nF 650 V

Typical AC Voltage Performance, EIA 3640 (CKC33)

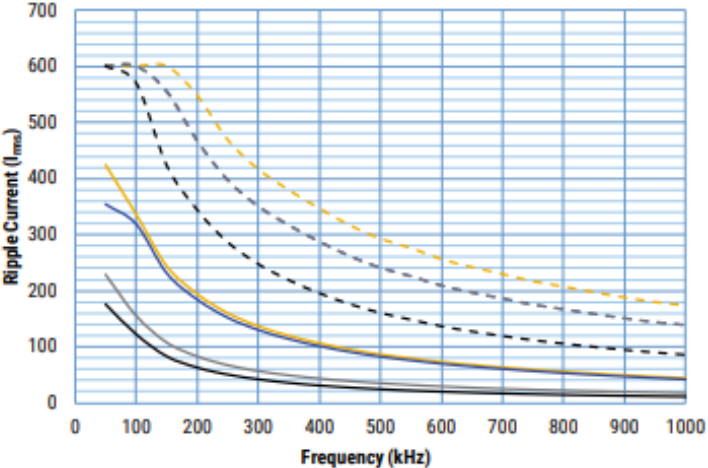

- 4.7nF 1700V
- 7.5nF 1700V
- 8.2nF 1700V
- 22nF 1700V
- 47nF 1200V
- 56nF 1000V
- 150nF 650V
- 220nF 500V

U2J with KONNEKT™

KEY BENEFITS

- ✓ U2J dielectric has a linear TCC curve with better performance than X7R.
- ✓ Cap up to 2X C0G dielectric.
- ✓ Extended cap ranges with 50V rating suitable for 48V DC-DC power supply Applications.

NOW AVAILABLE

Case Size (in)	Chips per stack	Cap	Voltage (Vdc)
1812	2	940 nF	50
1812	3	1.4 μ F	50



STANDARD

[View Datasheet](#)



LOW-LOSS

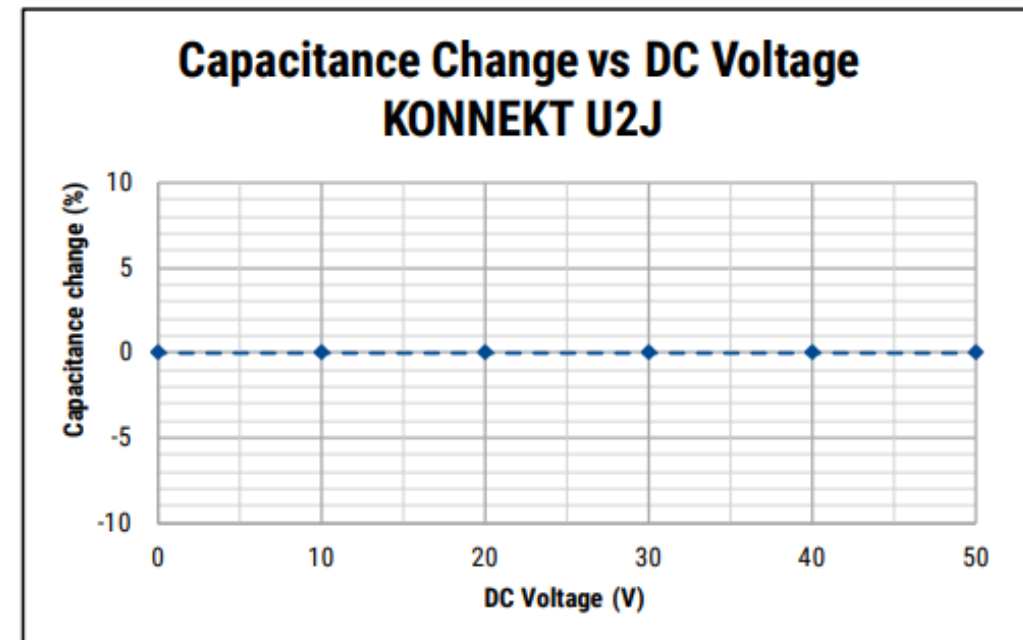
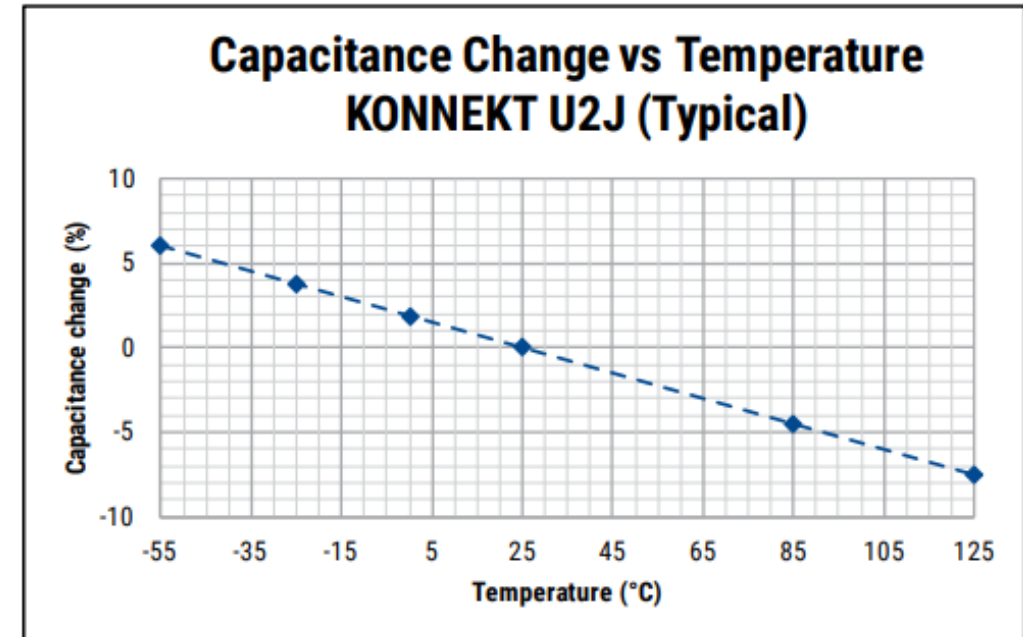

U2J with KONNEKT™

TYPICAL PERFORMANCE

Part Type	Mounting Configuration	Typical ESR at 25°C, 100 kHz	Typical ESL at 25°C	Typical Ripple Current (A_{rms}) ¹		
				100 kHz	200 kHz	300 kHz
1812 940 nF	Standard	1.15 mΩ	1.1 nH	12.0	12.0	11.5
	Low Loss	0.77 mΩ	0.45 nH	18.0	18.0	16.0
1812 1.4 uF	Standard	1.3 mΩ	1.6 nH	11.0	10.0	10.0
	Low Loss	0.35 mΩ	0.4 nH	20.0	34.0	31.0

UJ 1812 940nF

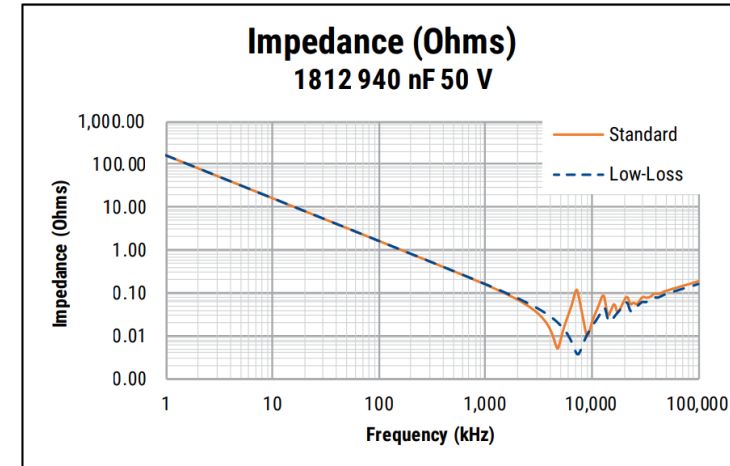

UJ 1812 1.4uF

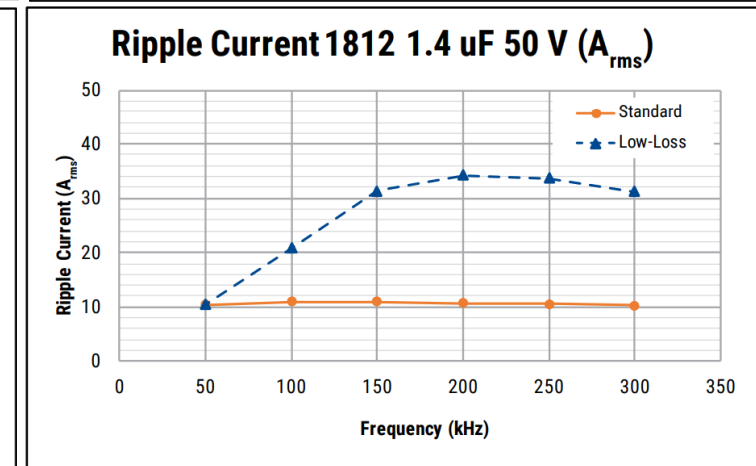
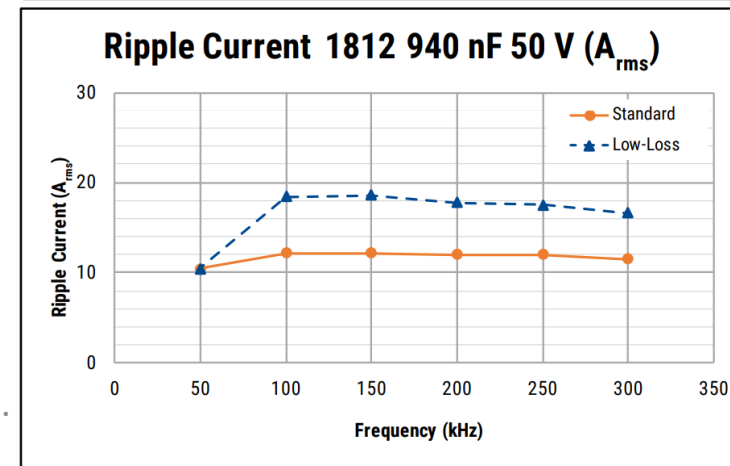
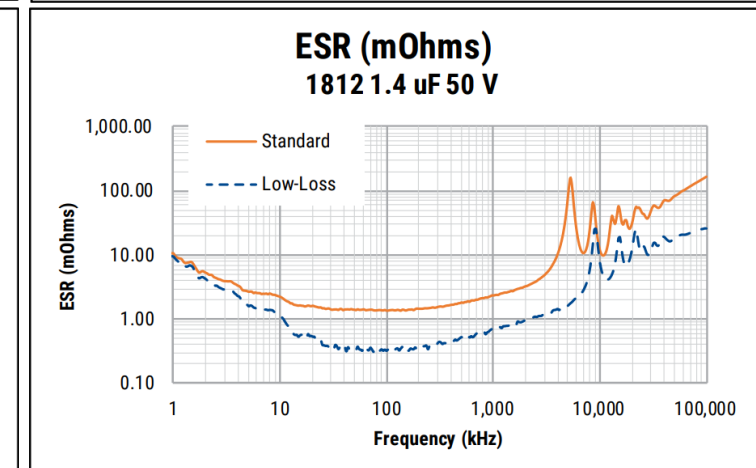
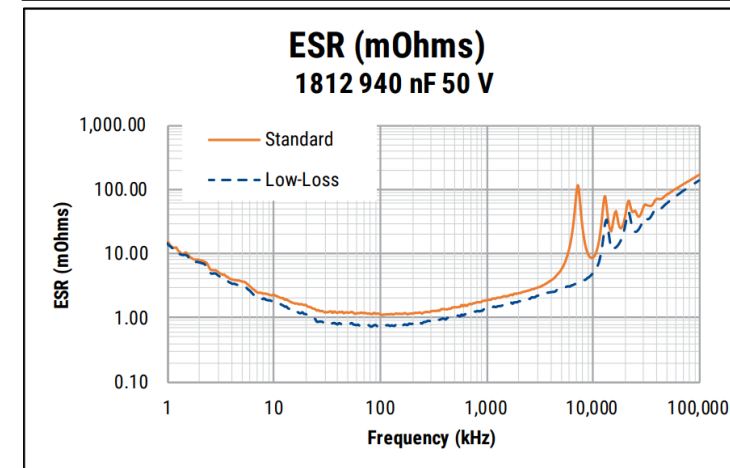
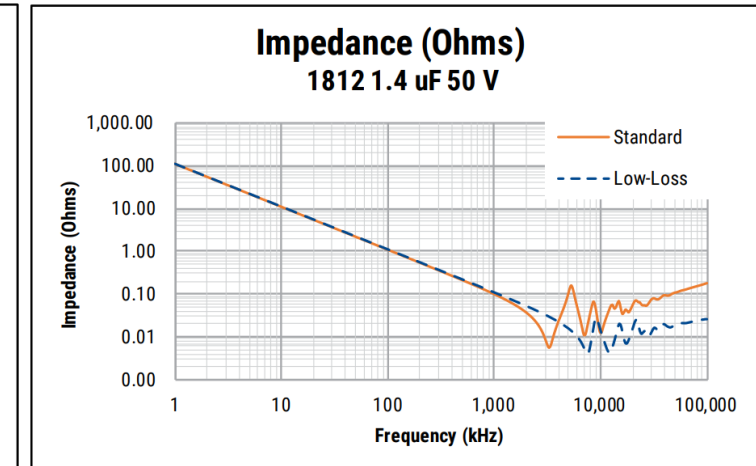

KEMET
a YAGEO company



KONNEKT™

High Density Packaging

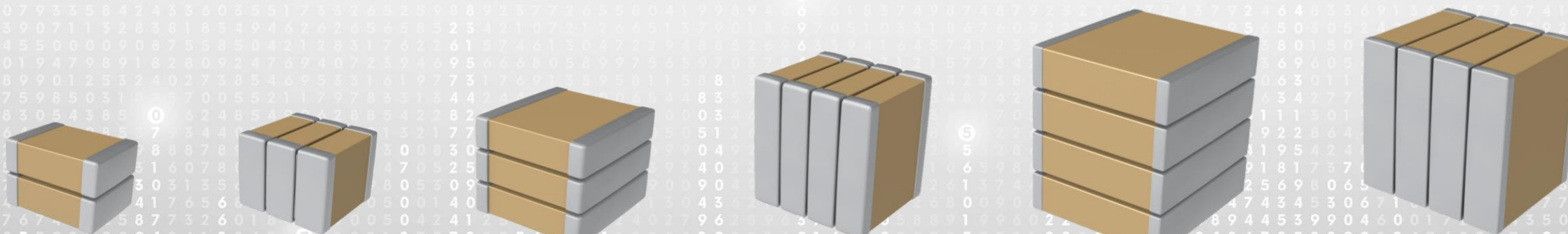

What is *KONNEKT*TM ?

KEMET *KONNEKT*TM is a **high density packaging technology** that allows components to be bonded together without leads.

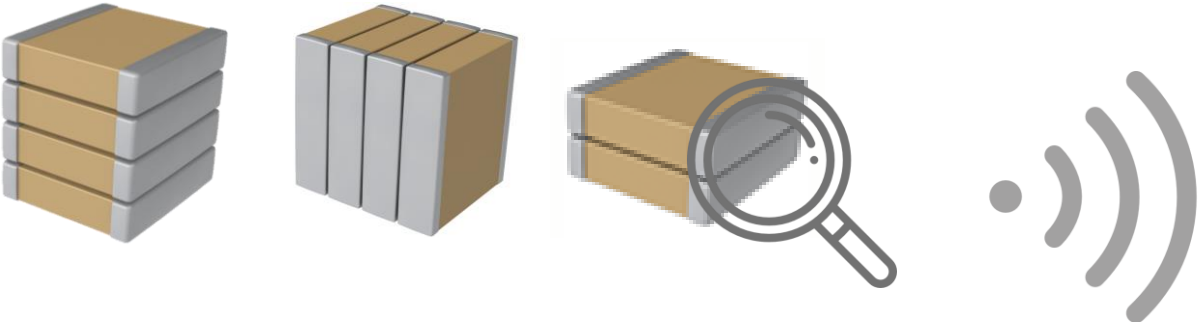

Multilayer Ceramic Capacitors (MLCCs) packaged in this way are surface mountable using normal pick-and-place and SAC reflow processing.

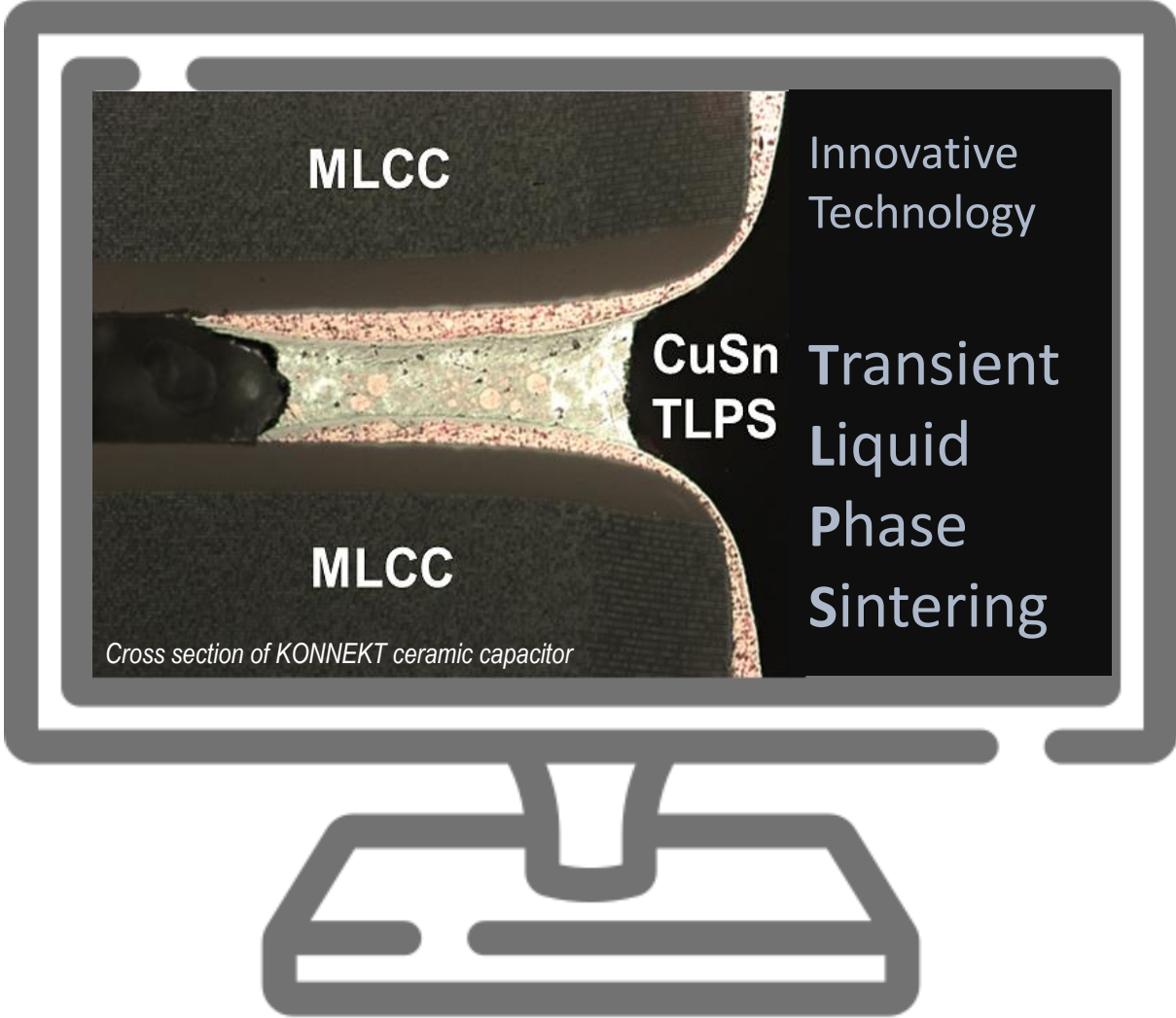

TLPS characteristics

Characteristics

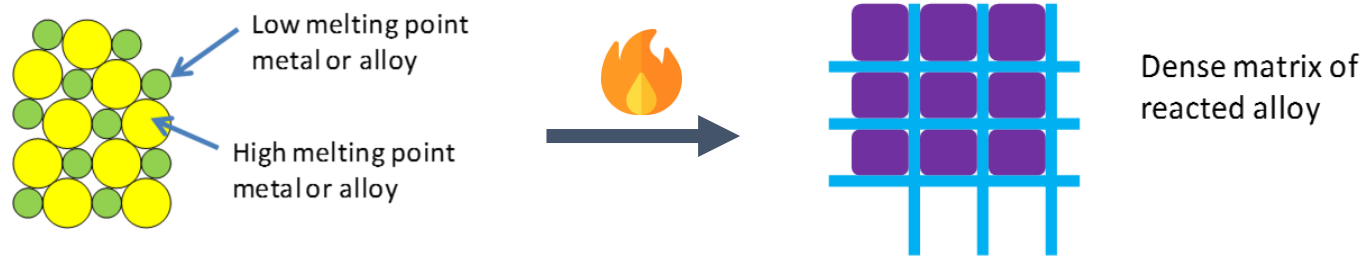

- Low temperature reaction of low melting point metal or alloy with a high melting point metal or alloy to form a reacted metal matrix.
- Forms a metallurgical bond between 2 surfaces
- Cu-Sn alloy
- Conducts like a solder
- High shear strength

Sintering process

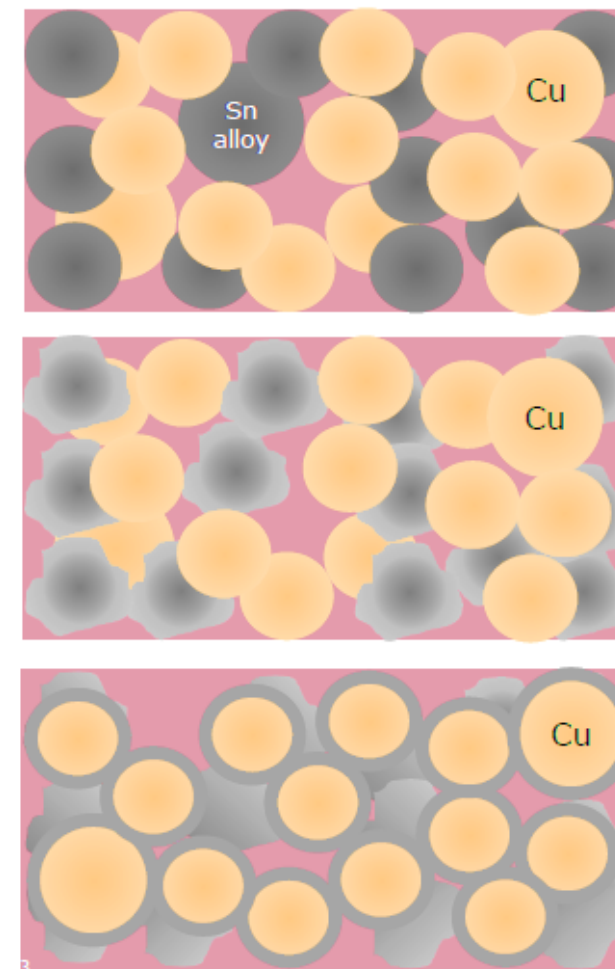

- Room Temp**
Cu and Sn-alloy particles are suspended in a flux vehicle
- ↓
- Sn-alloy Melt Temperature**
Alloy particles melt and wet the copper particles and metallized surfaces
- ↓
- Peak Sintering Temperature**
Sn and Cu interdiffuse to form new alloys with melting temperatures $>400^{\circ}\text{C}$

Creating Solutions Using KONNEKT Technology

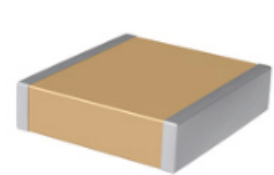

KC-LINK + KONNEKT Technology

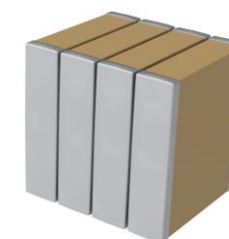
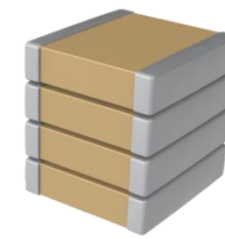
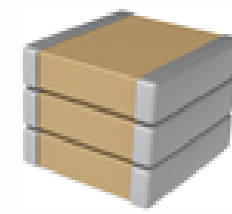
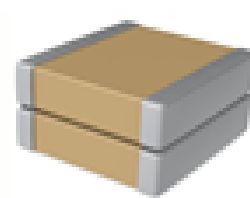

= KC-LINK with KONNEKT Technology

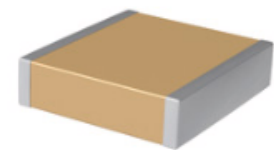

U2J + KONNEKT Technology



= U2J with KONNEKT Technology

KC-LINK with KONNEKT™

3640 KC-LINK with KONNEKT expands Capacitance and Voltage offerings.

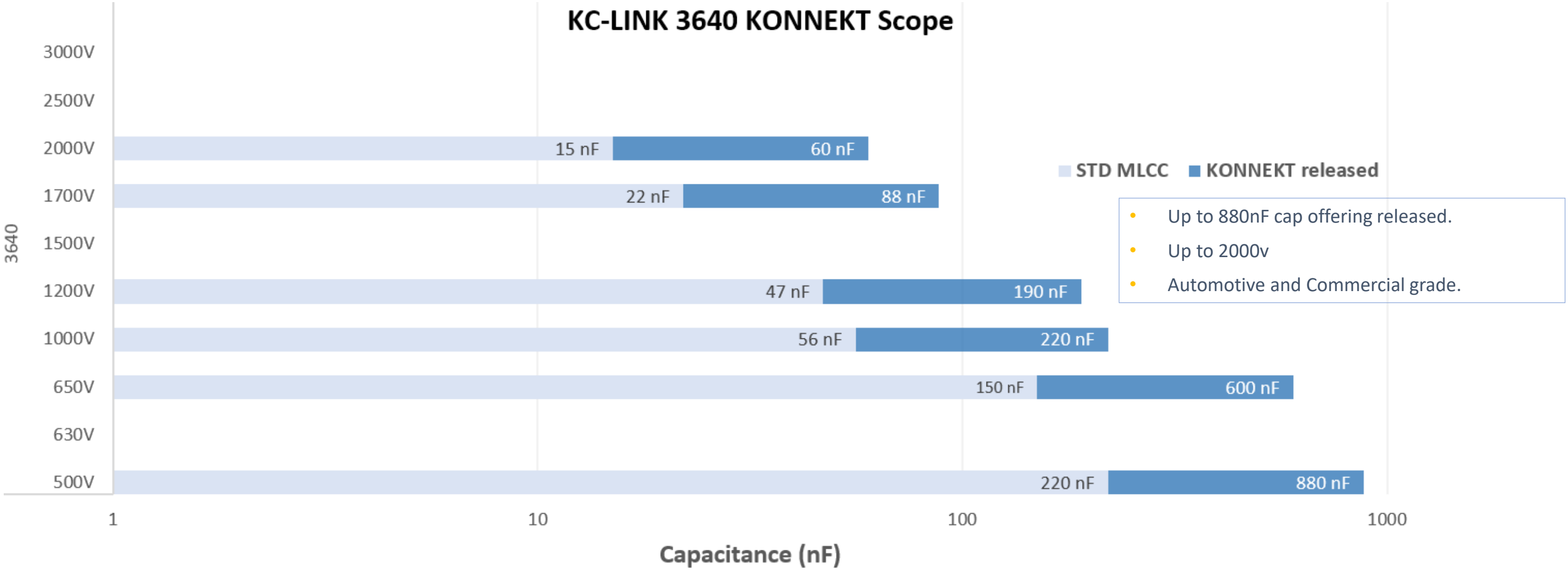

- Up to 880nF cap offering released.
- Up to 2000v
- Automotive and Commercial grade.

Two mounting orientations

STANDARD

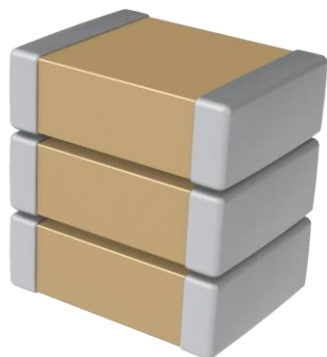

LOW - LOSS

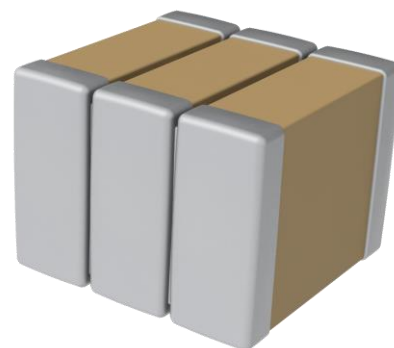

Low-Loss Benefits

- ✓ Lower ESR.
- ✓ Lower Thermal Resistance.
- ✓ Lower Inductance.
- ✓ Higher Ripple Current.

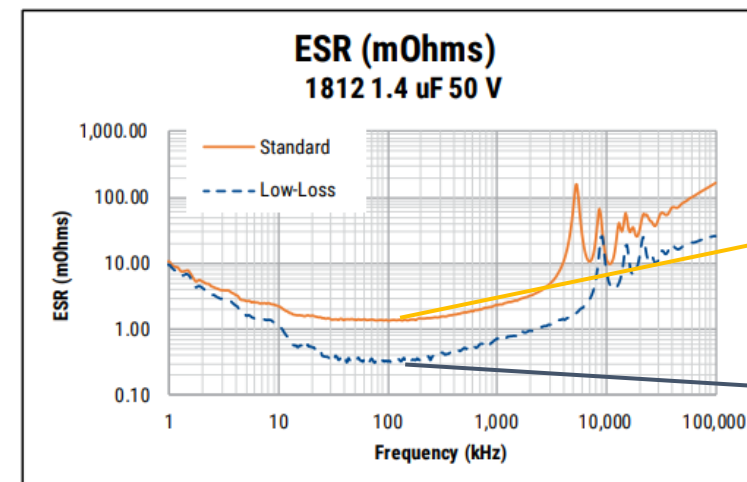

1.30 mΩ



0.35 mΩ

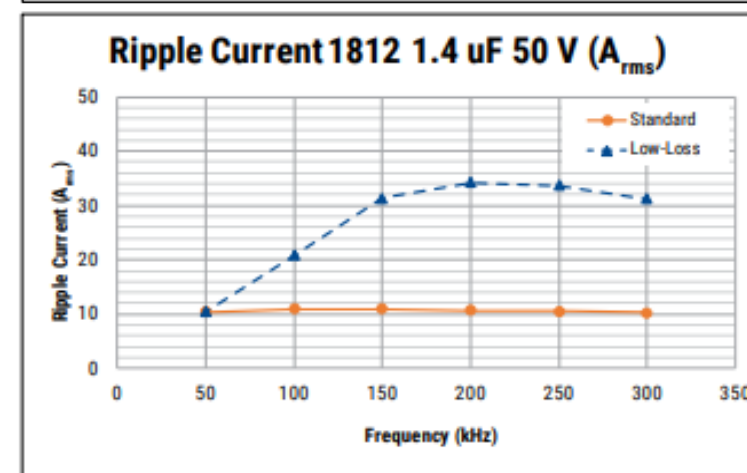

ESL

Standard	1.6 nH
Low-Loss	0.4 nH

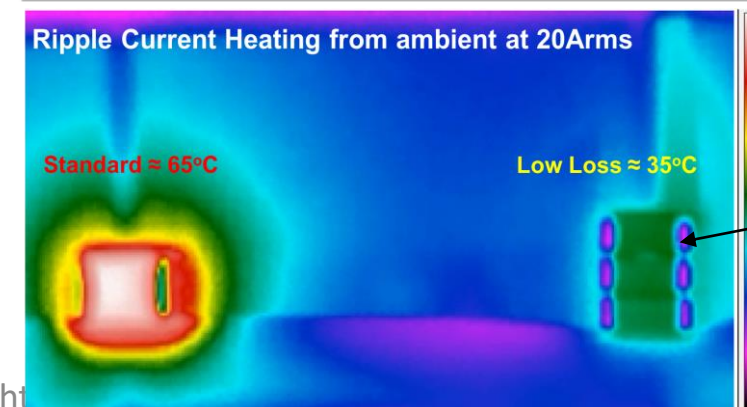

Lower i^2R Losses

KONNEKT Roadmap



RESONANT APPLICATIONS

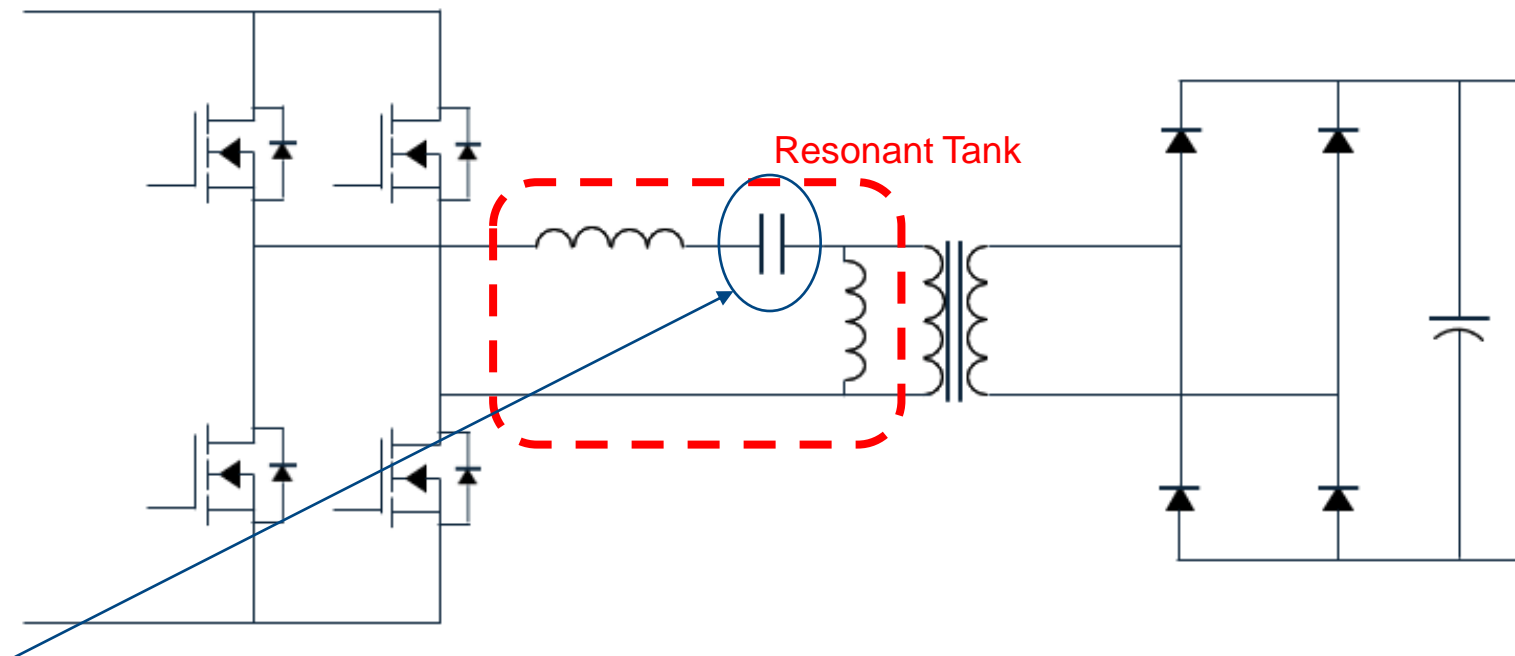

Resonant Capacitor

- Low voltage or high voltage depending on application
- Low ESR
- High Ripple Current
- Capacitance stability (voltage/temperature)
- Frequency range usually between 100kHz to a few MHz

RESONANT APPLICATIONS

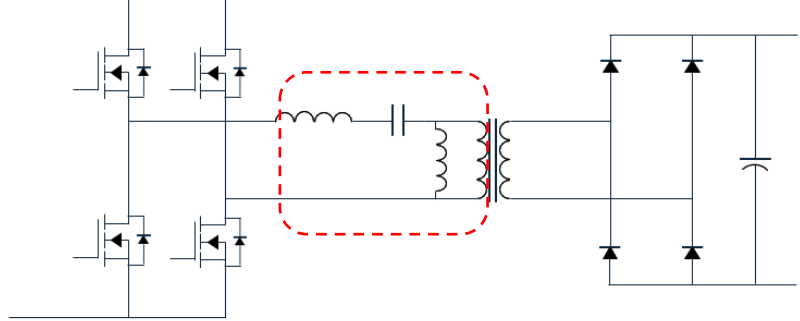

Application Details

- Utilizes a resonant topology
- Used in low voltage and high voltage applications
- Can be used with WBG semiconductors
- Datacenter/server applications
- On-board-chargers (OBC)
- Power converters

Benefits

- Drastically reduces switching losses (ZVS - Zero Volt Switching)
- Very high efficiencies achievable (up to 98%)
- High frequency operation → Smaller passives
- Wide voltage range

Switched Tank Converters for 48V to 12V Power Conversion have 98.92% efficiency

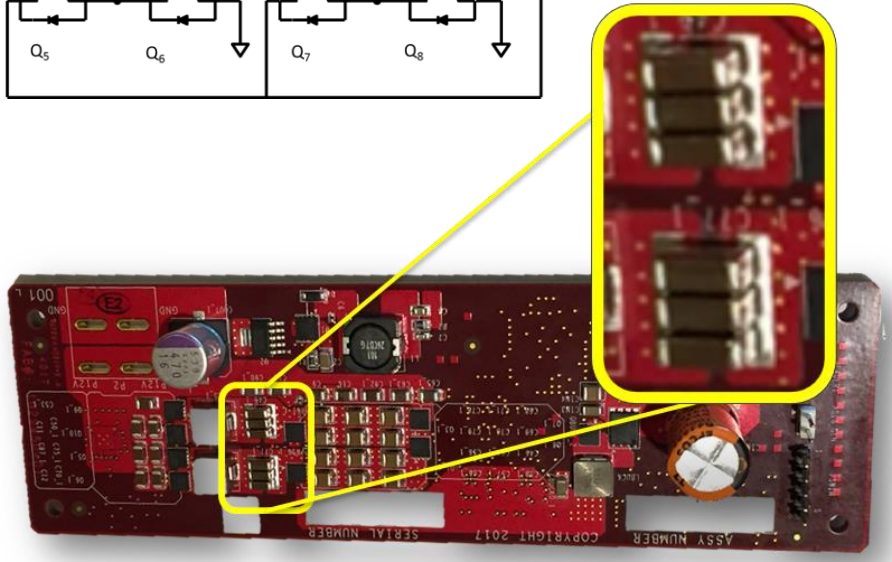
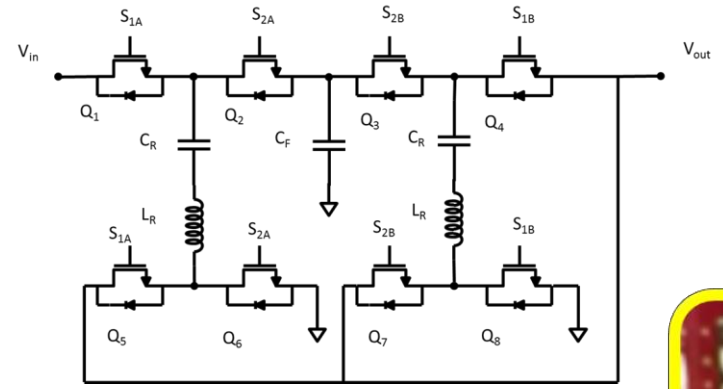

©KEMET Corporation. All Rights Reserved.

RESONANT WIRELESS POWER TRANSFER APPLICATIONS

BENEFITS

- ✓ Wireless
- ✓ High power transfer capability
- ✓ High efficiency

DETAILS

- ✓ Utilizes resonant topology
- ✓ Stationary charging
- ✓ Dynamic charging (while driving)

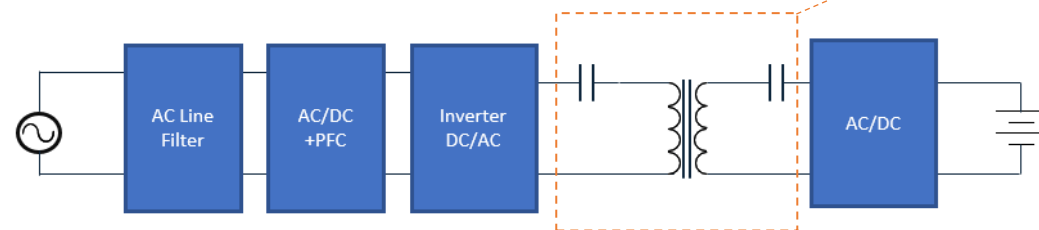
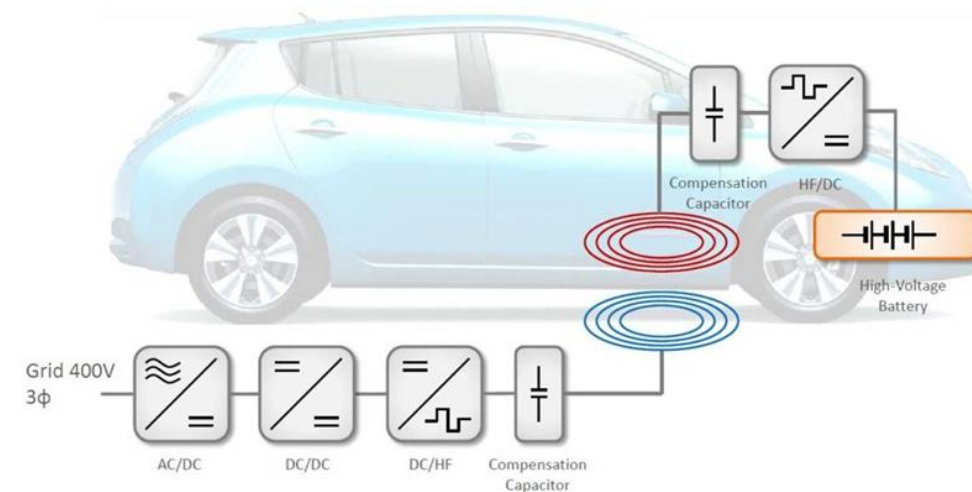

©KEMET Corporation. All Rights Reserved.

RESONANT CAPACITOR

- High AC voltage & current
- Frequently uses series/parallel combination of capacitors.
- Low ESR
- High Ripple Current
- Capacitance stability (V & °C)
- Frequency range 10KHz – 100KHz (85KHz nom)

SUMMARY

- Power electronics are being ever-more demanding
- WBG semi is the solution to the demands of PE
- Transition to WBG is causing passives to be pushed to new limits
- Class I ceramic caps and novel packaging ideas are positioned as solutions

THANKS!

For More Information Contact:

WilmerCompaniononi@KEMET.com