

ENERGY  
THAT  
CHANGES



**UCC**  
Coláiste na hOllscoile Corcaigh, Éire  
University College Cork, Ireland



THAYER SCHOOL OF  
ENGINEERING  
AT DARTMOUTH

# MAGNETIC CORE DIMENSIONAL EFFECTS – FLUX PROPAGATION IN FERRITES

**2018-03-03 - Marcin Kącki, Marek Ryłko, Edward Herbert,  
John Hayes, Charles Sullivan**

# Content



<b>1</b>	<b>Introduction</b>
<b>2</b>	<b>Magnetic material comparison and permeability characteristic</b>
<b>3</b>	<b>Magnetic flux distribution experimental investigation</b>
<b>4</b>	<b>Ferrite ring core – flux distribution</b>
<b>5</b>	<b>Ferrite frame core – flux distribution</b>
<b>6</b>	<b>Conclusion and future work</b>

# Introduction – Work Motivation



A number of high frequency effects are not considered in a typical EMI choke design.

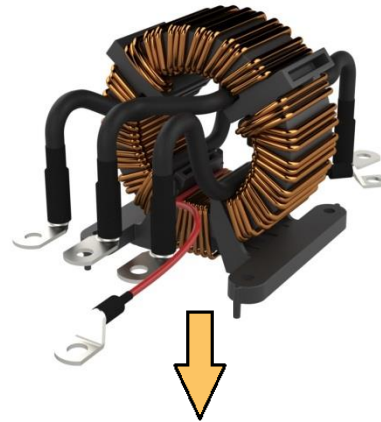

High power systems exhibit unexpected deterioration of magnetic material performance.

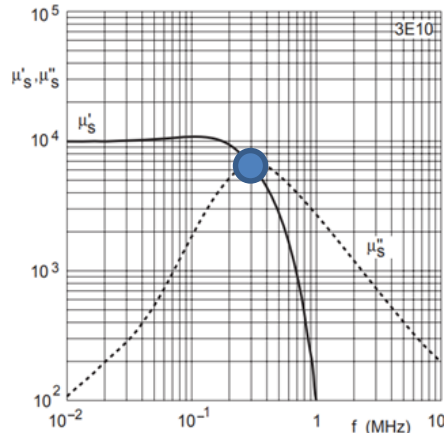

Complex permeability as a function of frequency

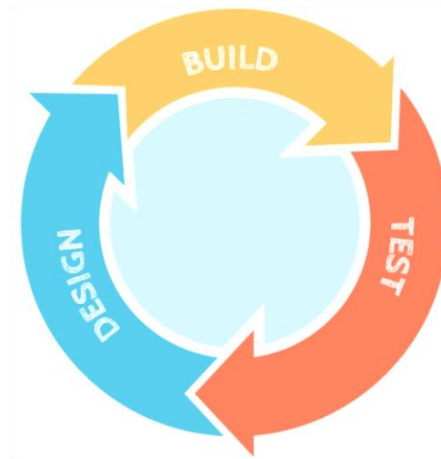

**This work is to improve EMI choke design approach with high frequency effects.**

# Magnetic Materials



Magnetic material selection defines choke performance.

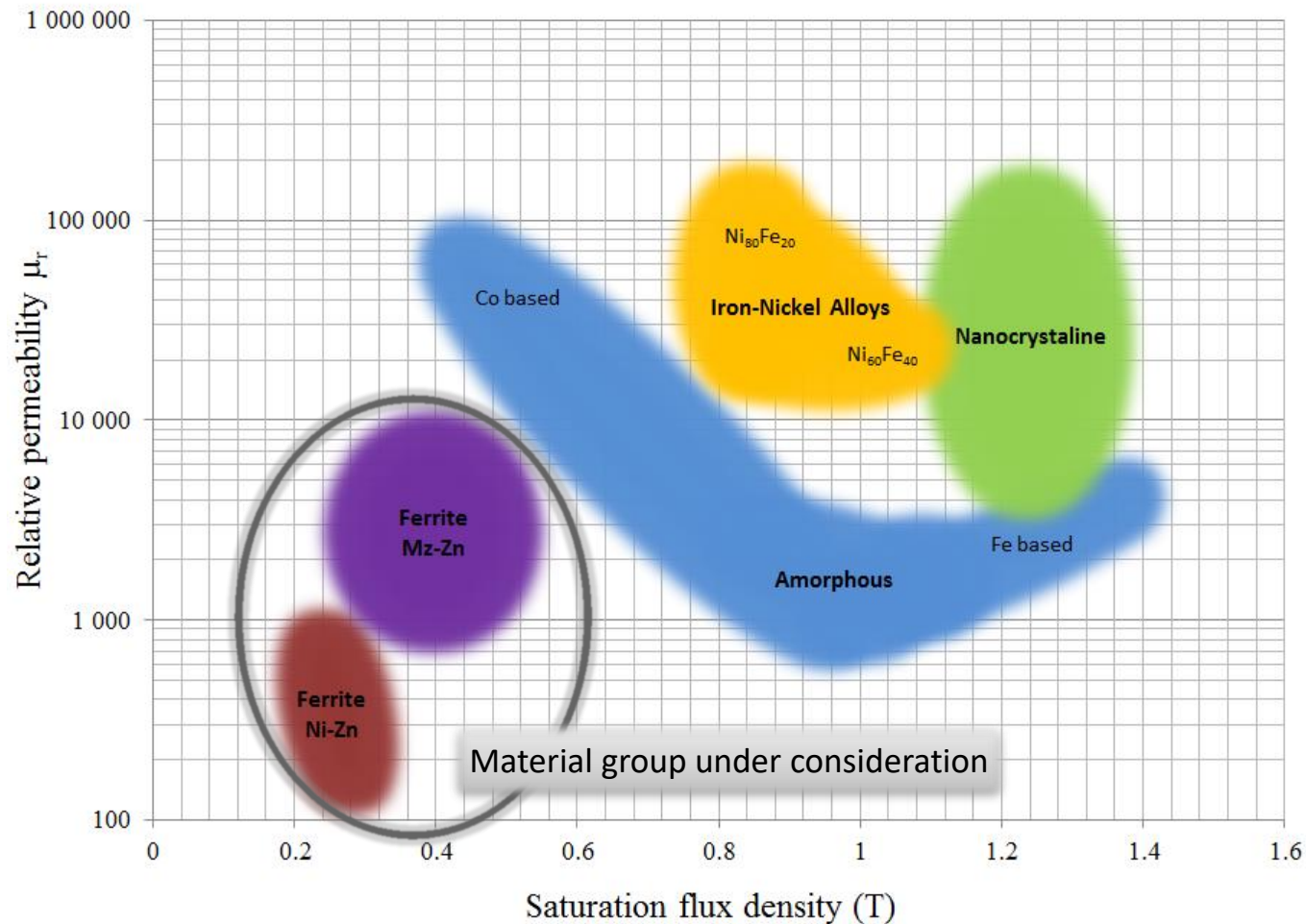

# Large Cores Permeability Drop in Ferrite Material



Ferroxcube 3E10 material permeability as a function of frequency for various core size.

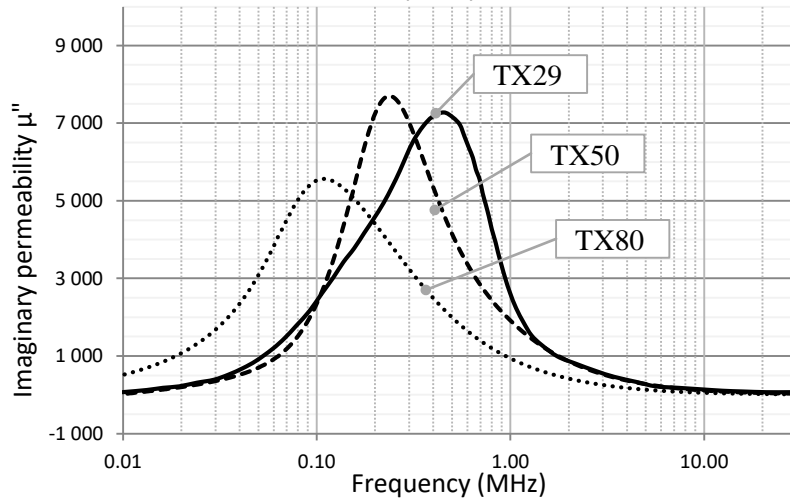
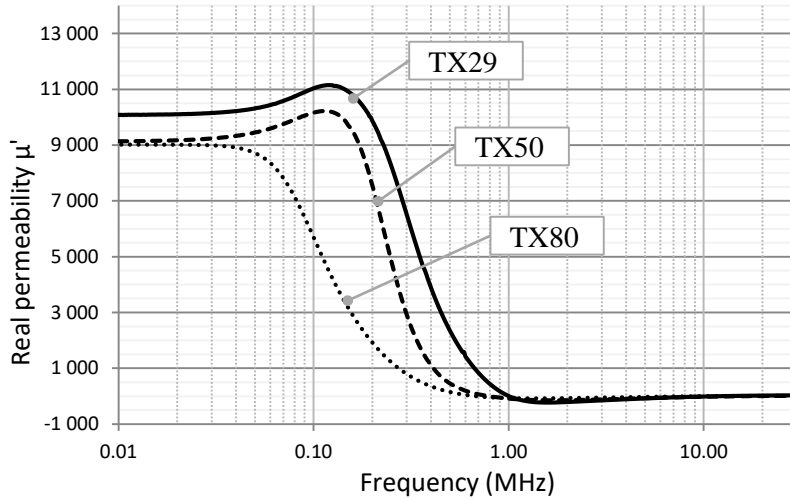

Magnetic flux undergoes skin effect similar to electric conductors.

$f = 10 \text{ kHz}$

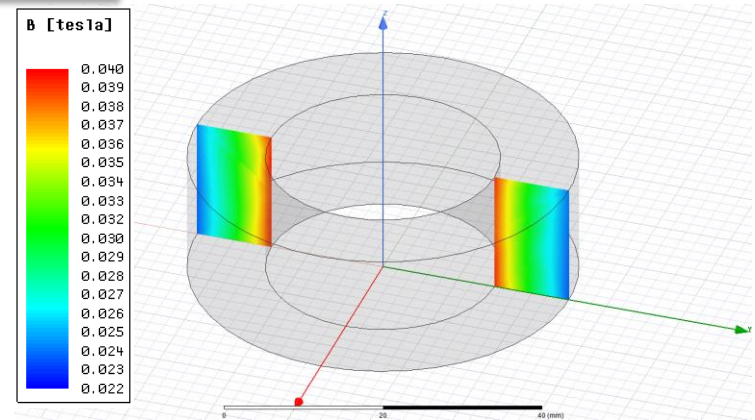

$f = 1 \text{ MHz}$

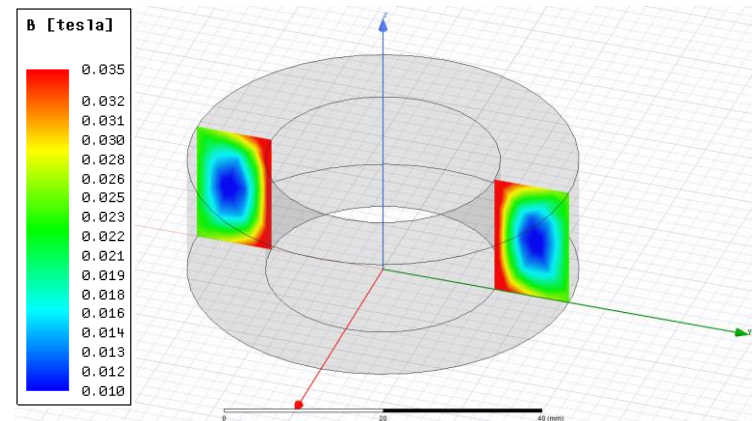

# Experimental Investigation



Four main experiments:

1. Flux distribution in the core  
Core is divided into 9 sections with wire loops, voltage of each loop is measured.
2. Flux distribution effect on the impedance  
Impedance vs. frequency in range between 1 kHz and 30 MHz is recorded.
3. Isolation of the reluctance effect from the skin effect  
Frame core is used to provide homogenous flux concentration in the core.
4. Analysis of various magnetic materials  
Investigation of the skin effect for various materials:

<i>Ring Core</i>	Material	Size	Type	Permeability (Manufacturer spec.)	Resistivity ( $\Omega\text{m}$ ) (Manufacturer spec.)
Ferroxcube	3E15	50/30/16.5	MnZn	15 000	0.5
Ferroxcube	3E10	50/30/16.5	MnZn	10 000	0.5
Ferroxcube	3E6	50/30/16.5	MnZn	10 000	0.1
Ferroxcube	4S60	50/30/16.5	NiZn	2000	$10^5$
FairRite	FR78	105/75/15	MnZn	2300	200
FairRite	FR61	105/75/15	NiZn	120	$10^9$

## *Frame Core*

Material	Type	Permeability (Manufacturer spec.)	Resistivity ( $\Omega\text{m}$ ) (Manufacturer spec.)
FR78	MnZn	2300	200
FR61	NiZn	120	$10^9$

# Experimental Investigation



An experimental investigation uses drilled ferrite cores. Each tested core has two vertical and one horizontal bores. Bore diameter is 0.75 mm. Vertical and horizontal bores allows to characterize 9 regions of the core cross section.

- Test I - Flux distribution in the core  
This test determine the voltage of each inner ferrite segment.
- Test II - Flux distribution effect on the impedance  
This test determine impedance and phase shift of each inner ferrite segment.

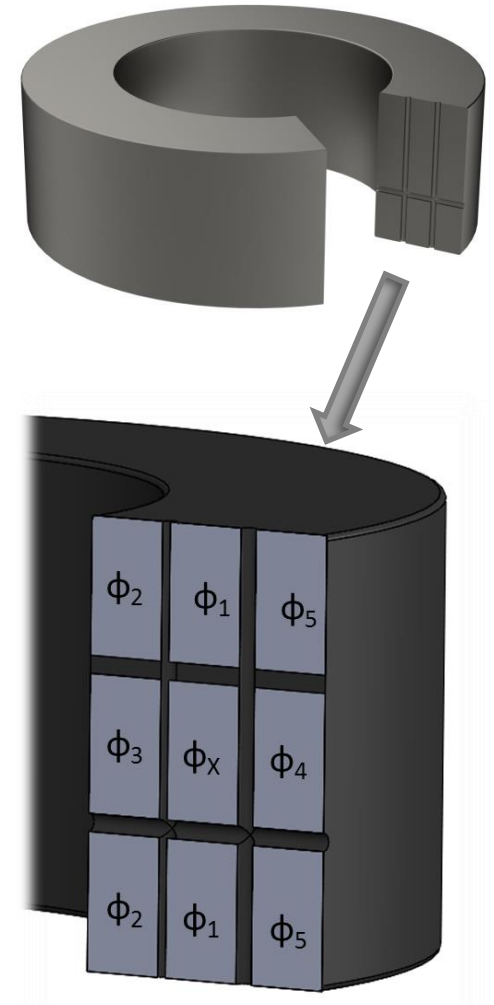

# Flux Distribution in the Ring Core- Test I



Test setup:

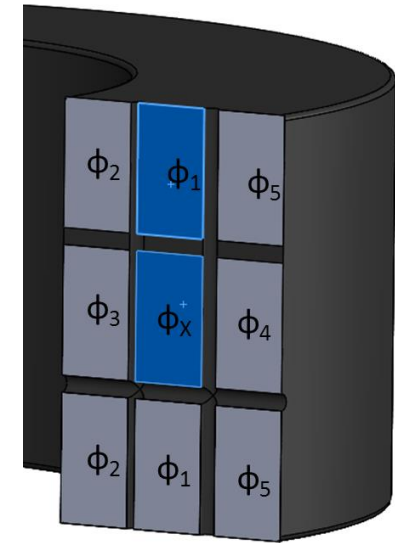
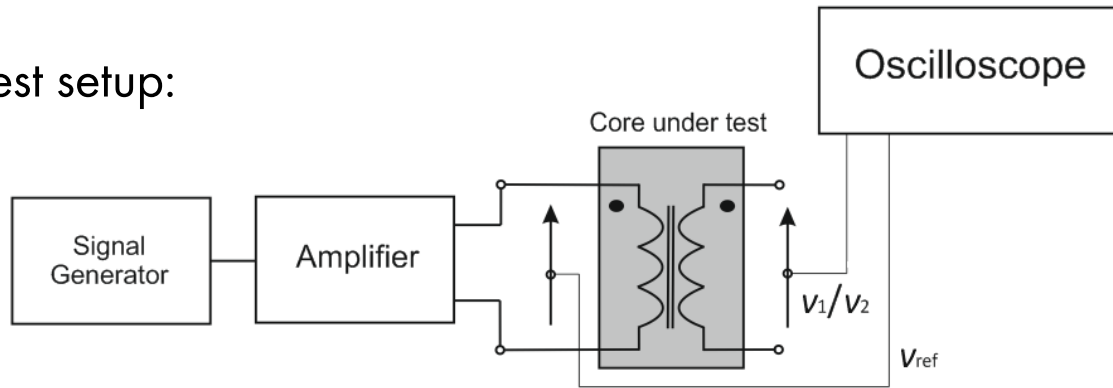

Ring core: T50/30/16.5mm MnZn 3E10 ferrite.

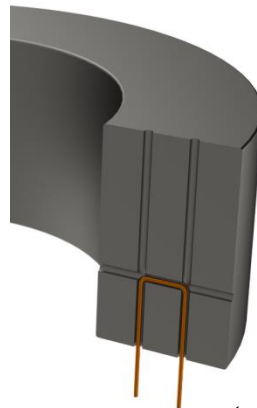
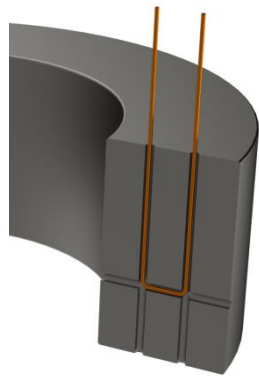

$$v_1(t) = V_{1M} \sin(\omega t + \varphi_1) \quad v_2(t) = V_{2M} \sin(\omega t + \varphi_2)$$

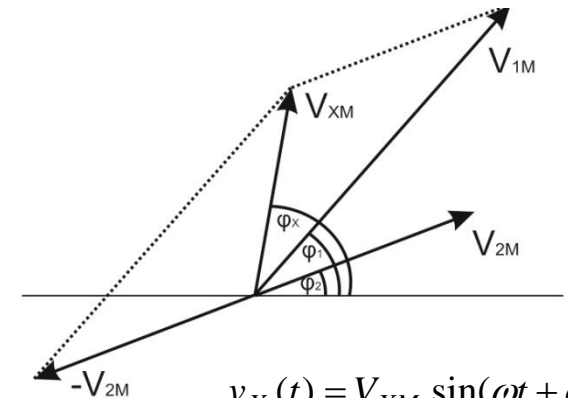

$$v_X(t) = V_{XM} \sin(\omega t + \varphi_X)$$

$$v_X(t) = v_1(t) - v_2(t)$$

# Flux Distribution in the 3E10 Ring Core - Test I

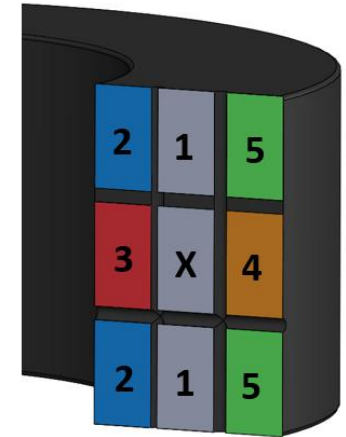
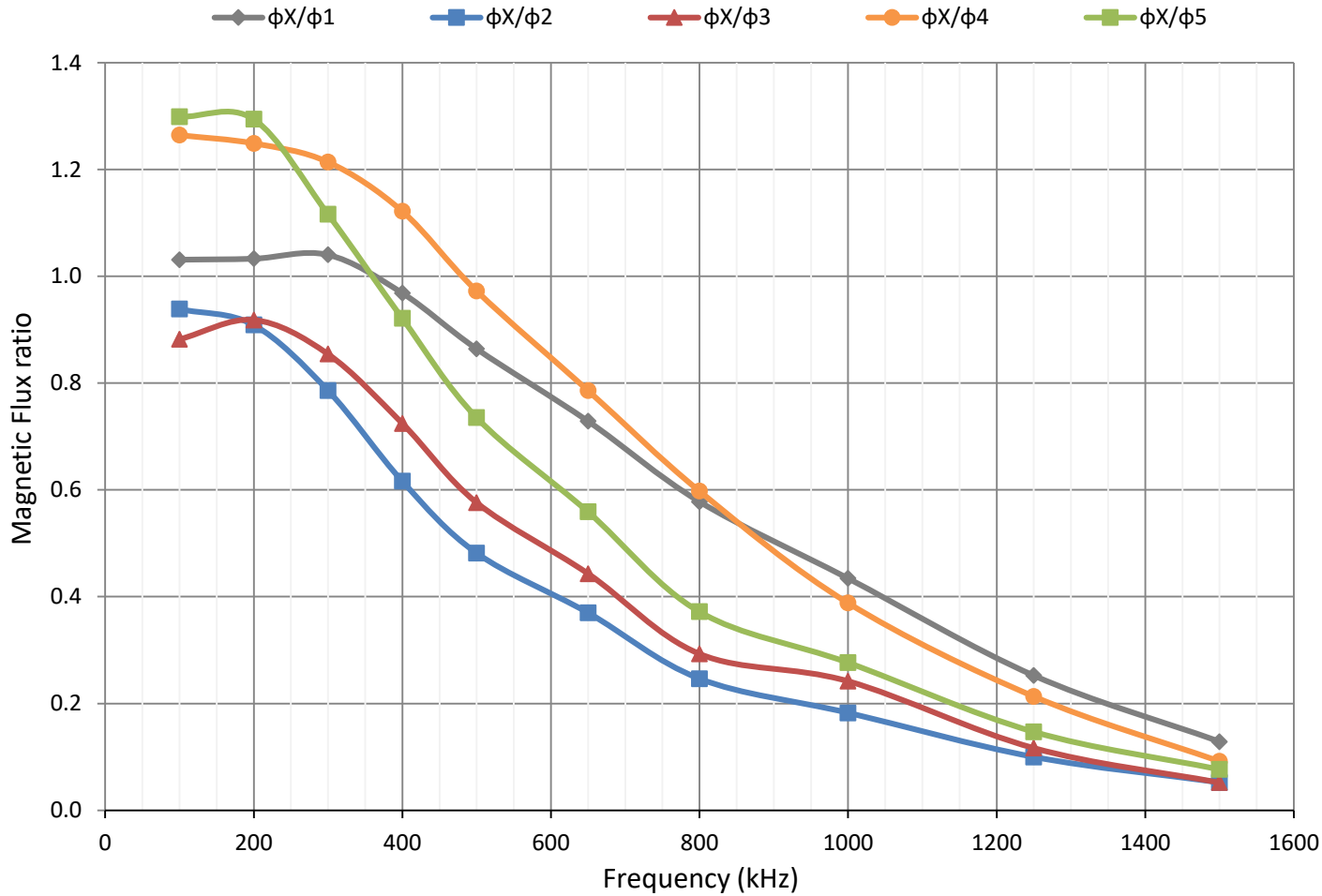

# Flux Distribution in the 3E10 Ring Core - Test I

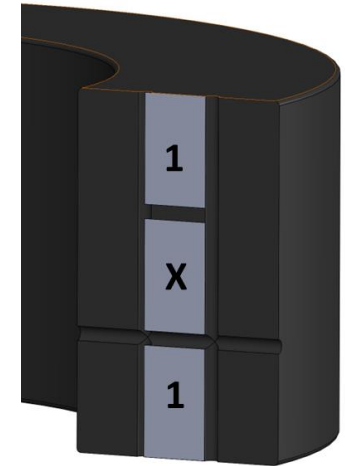
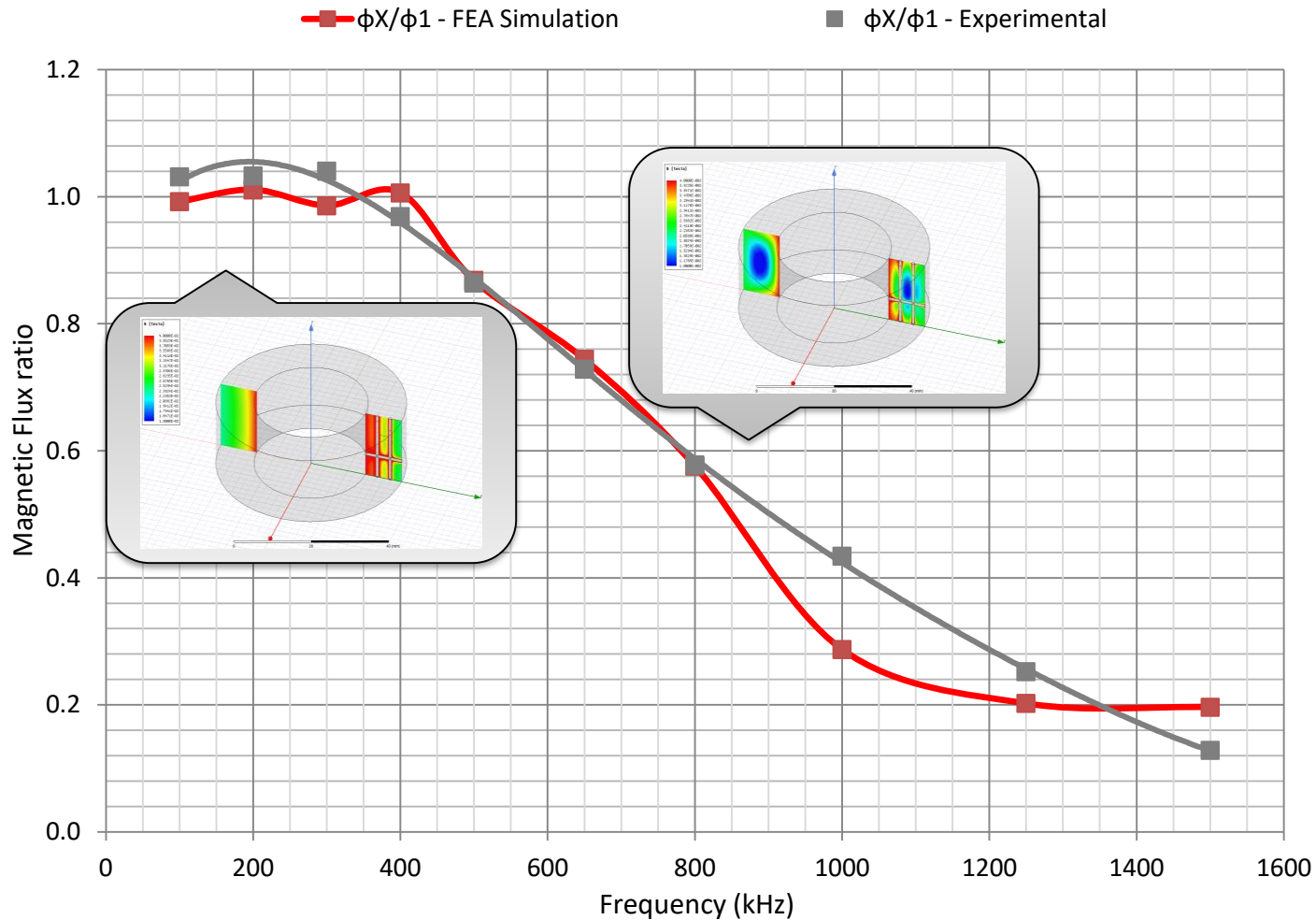

# Core Properties Comparison – 3E10 vs. 3E15 vs. 3E6 – Test I



## Ferrite 3E10 vs. Ferrite 3E6 vs. Ferrite 3E15

	Permeability (Manufacturer spec.)	Resistivity (Manufacturer spec.)
Ferrite 3E10	10 000	0.5 $\Omega\text{m}$
Ferrite 3E6	10 000	0.1 $\Omega\text{m}$
Ferrite 3E15	15 000	0.5 $\Omega\text{m}$

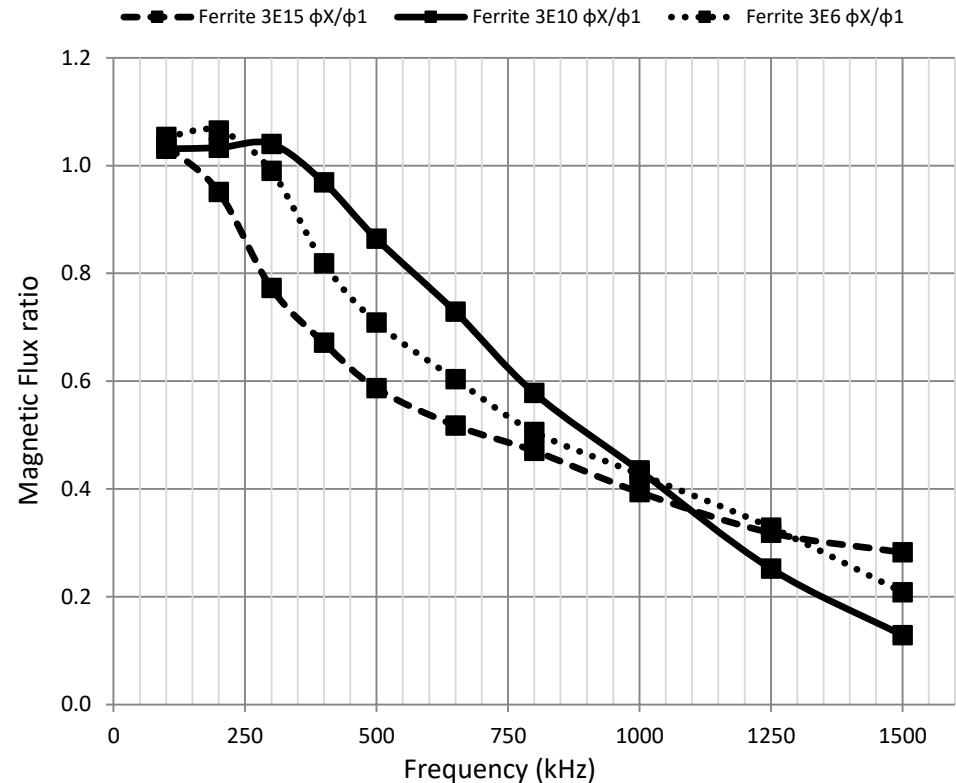

Flux skin depth depends on material conductivity, permeability and frequency.

# Flux Distribution Effect on the Impedance - Test II



Ring core:  
T50/30/16.5mm  
MnZn 3E10 ferrite.

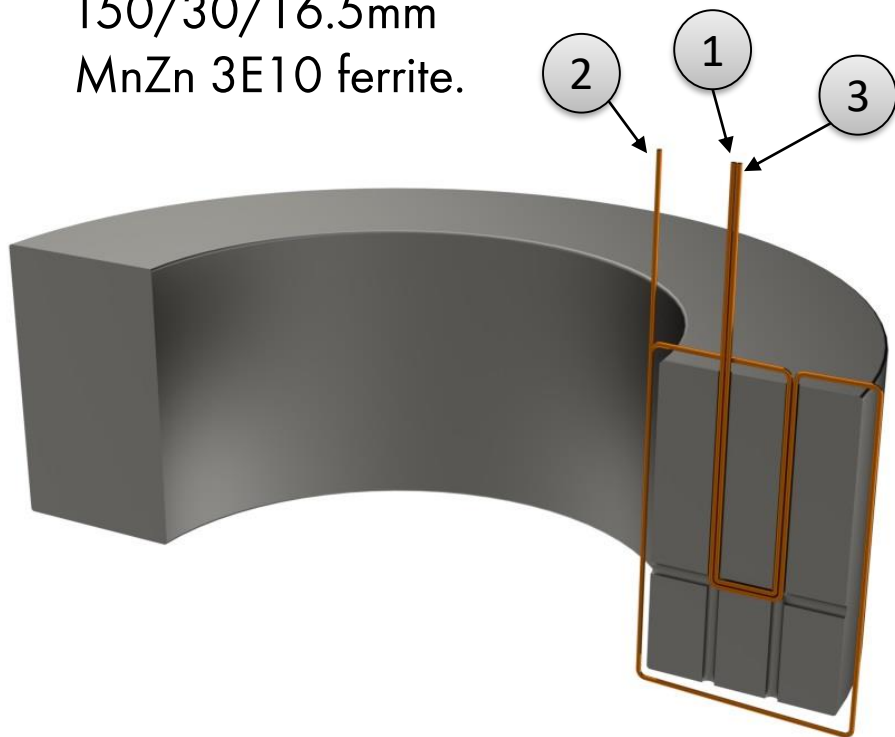

Impedance measurement test setup.

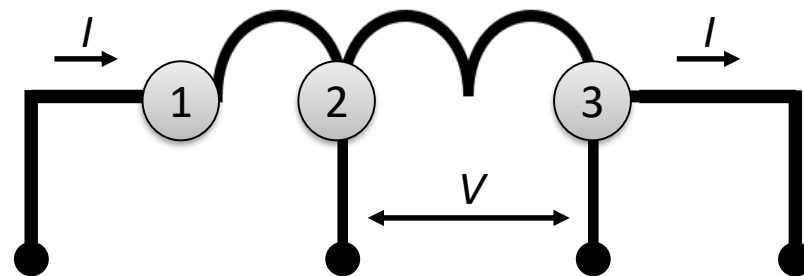
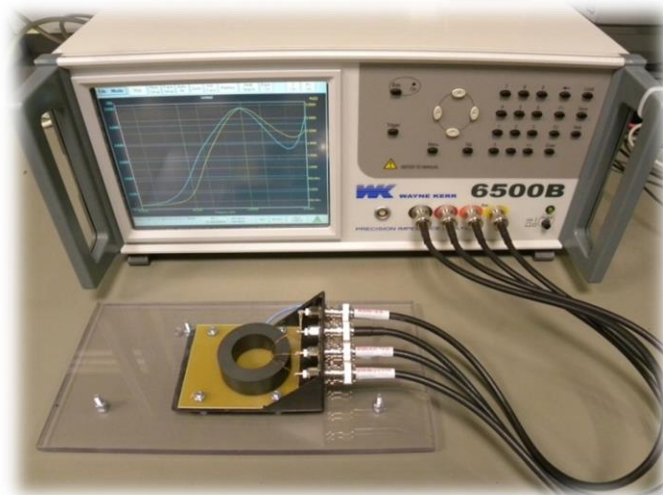

# Flux Distribution Effect on the 3E10 Ring Core Impedance - Test II

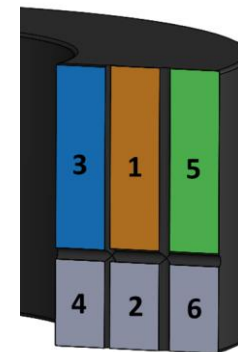

Impedance and phase frequency characteristic.

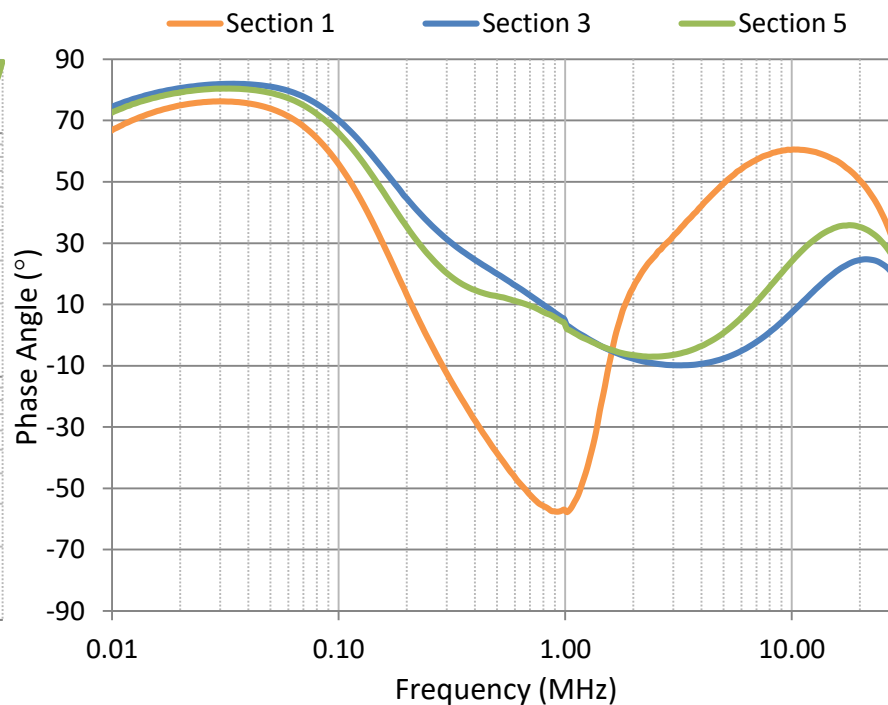
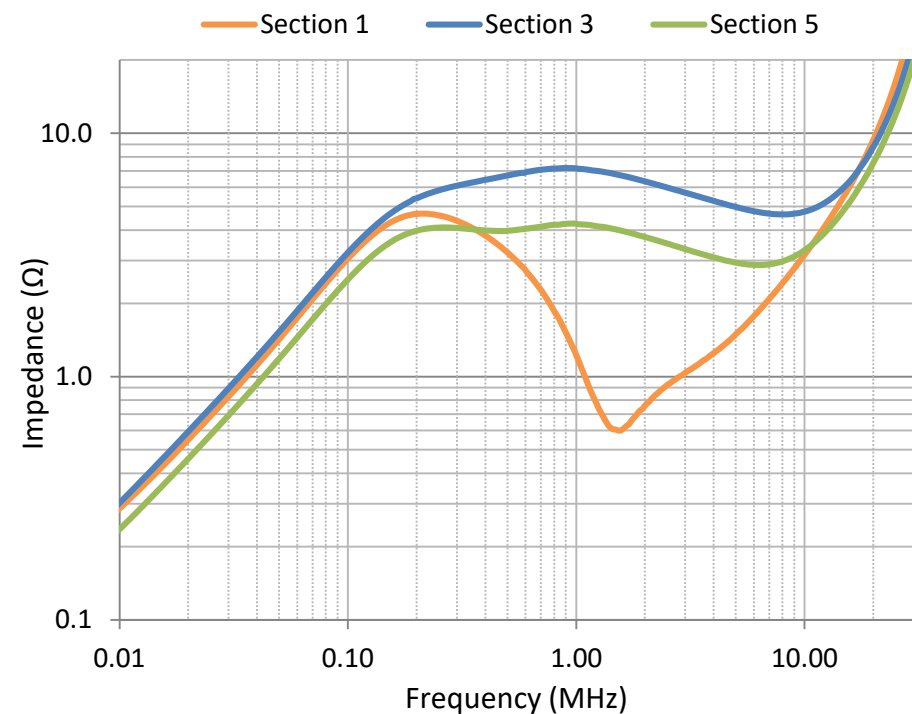

# Flux Distribution in the Frame Core – Test I



Frame core is used to mitigate flux concentration effect in order to expose core skin effect.

Frame core dimensions: 106/65/15mm  
MnZn ferrite material: FR78

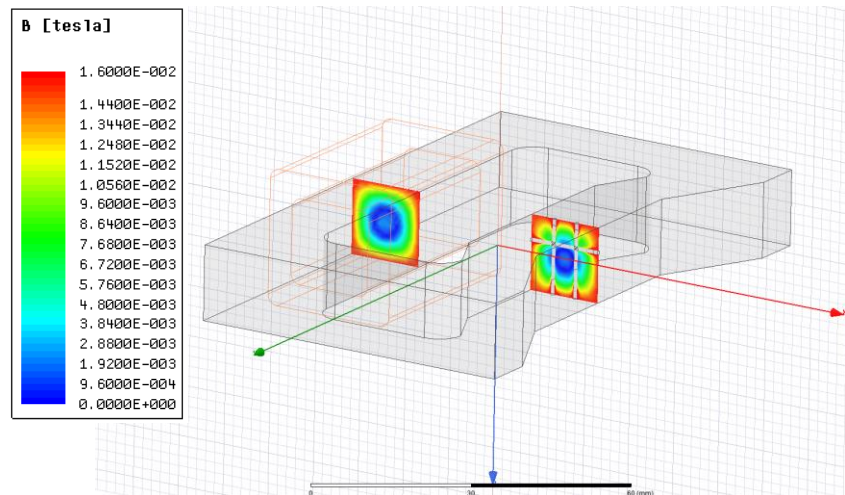
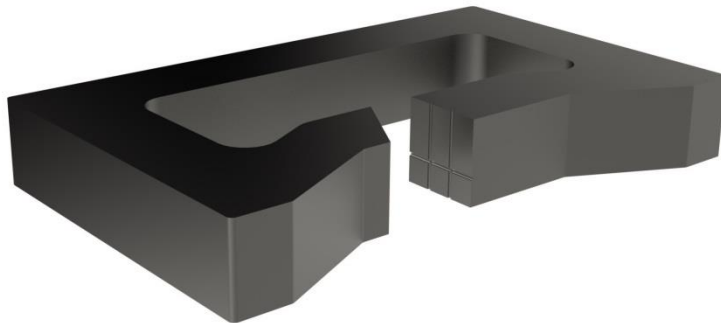
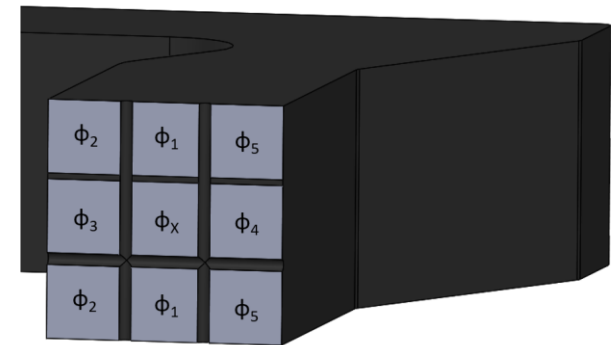

# Flux Distribution in the FR78 Frame Core - Test I

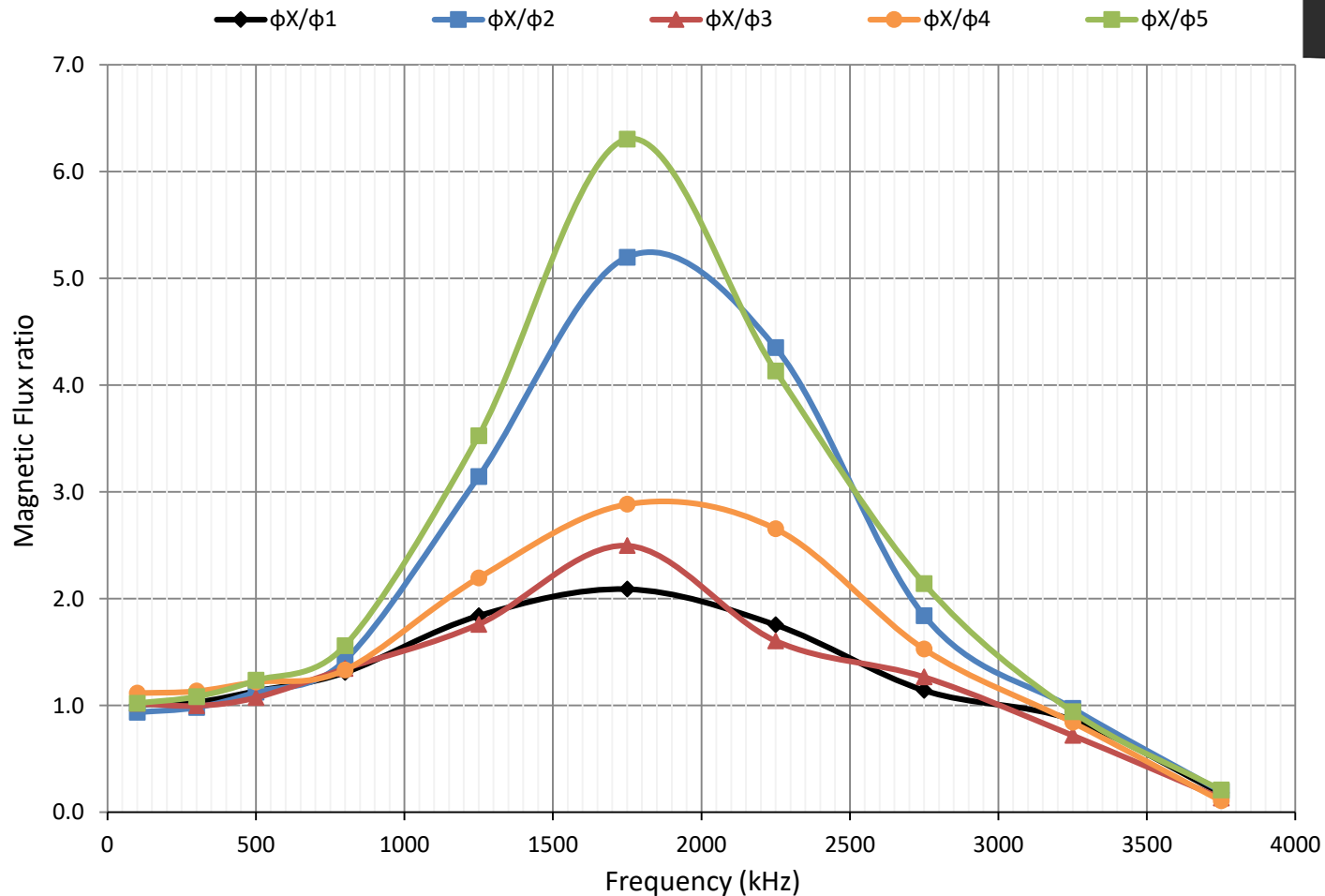
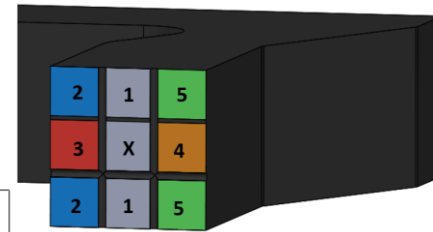

# Flux Distribution in the FR78 Ring Core - Test I

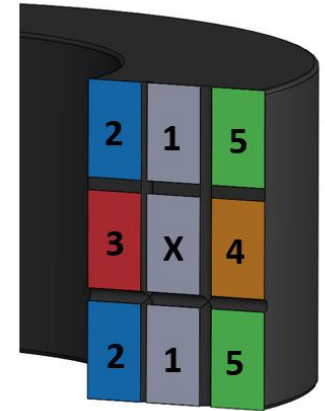
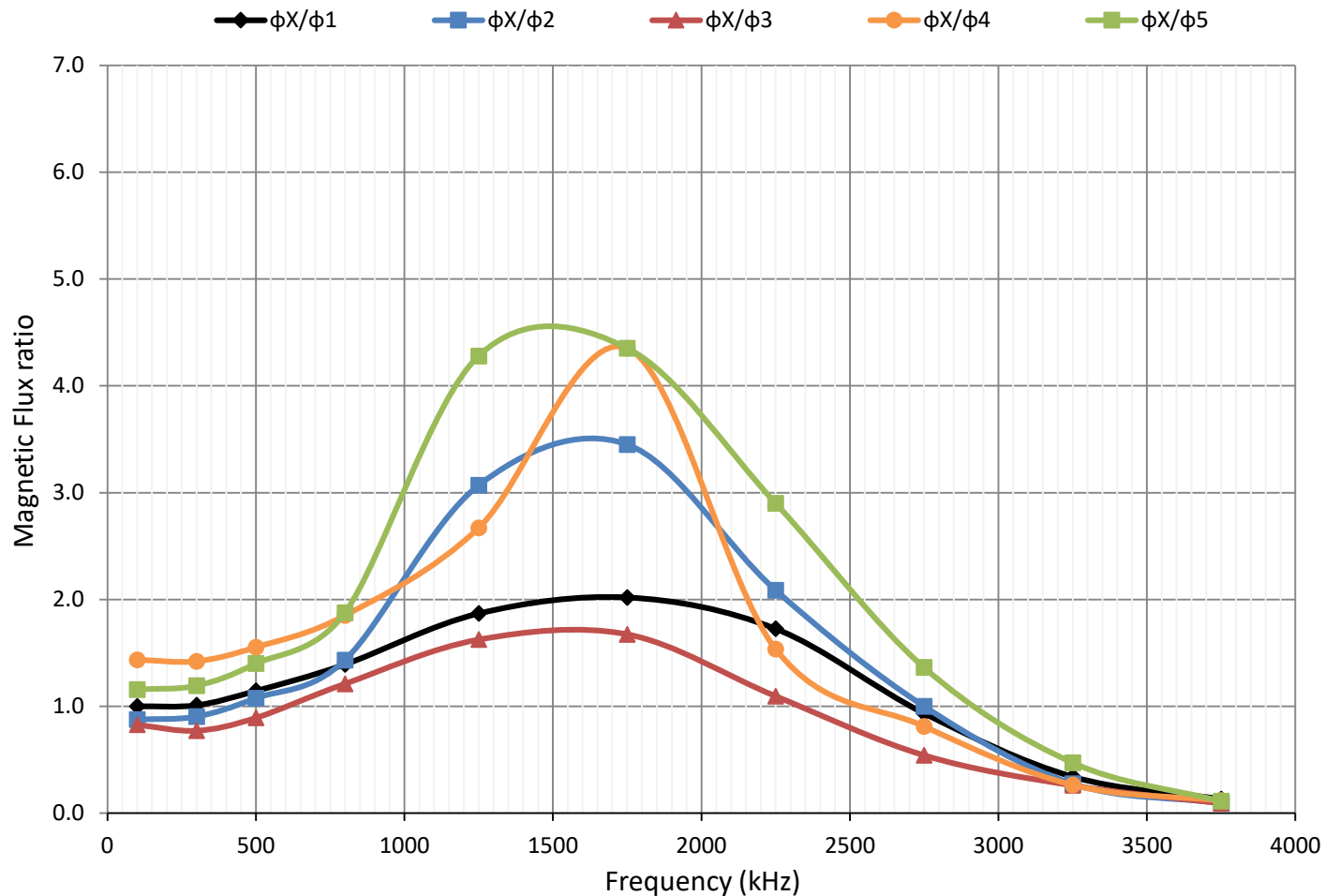

# Flux Distribution Effect on the Frame Core FR78 Impedance - Test II



Impedance and phase frequency characteristic.

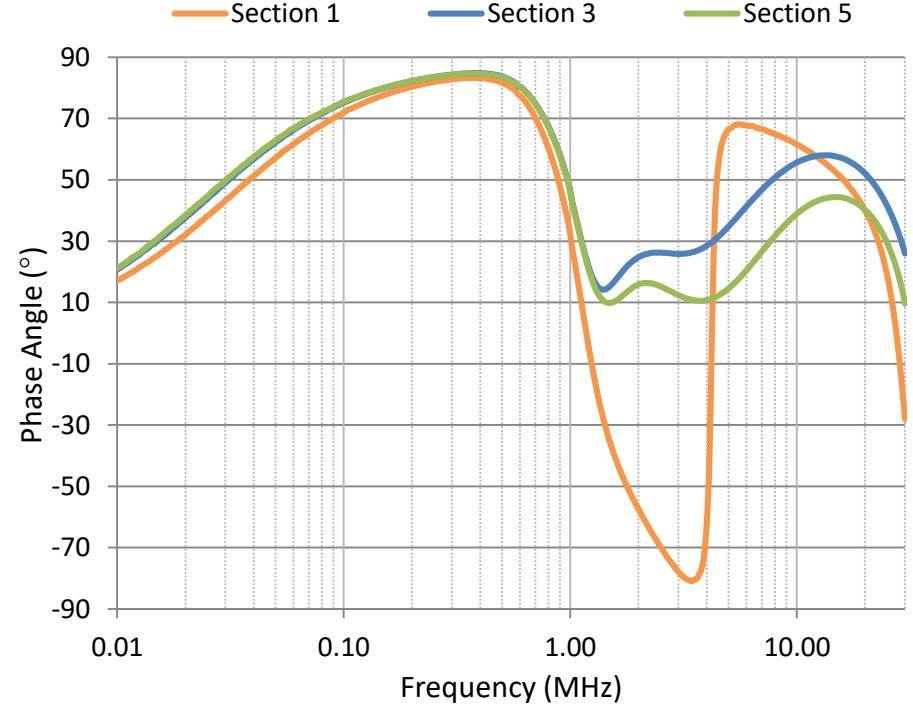
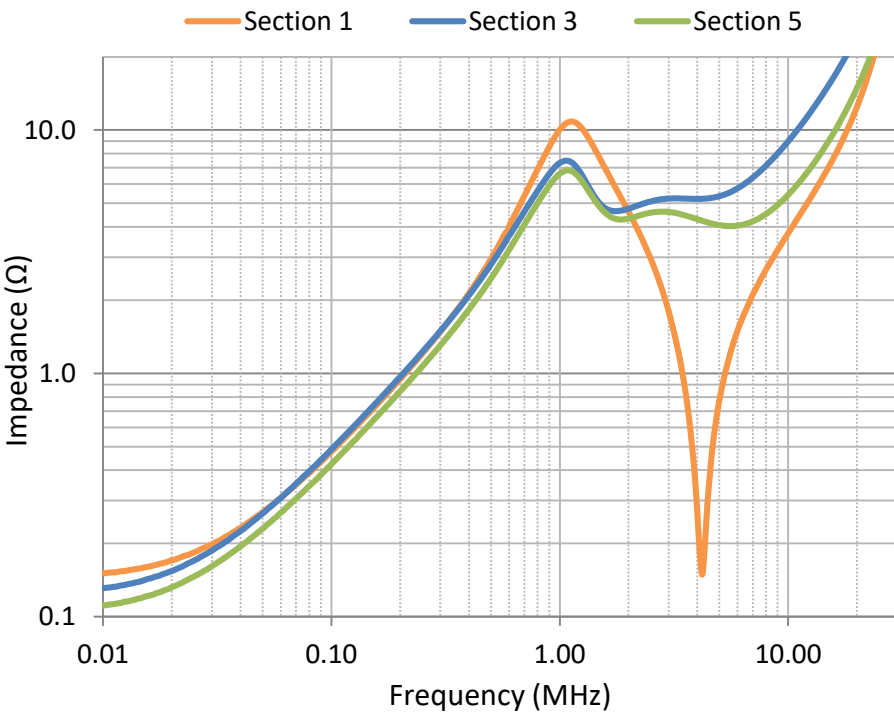
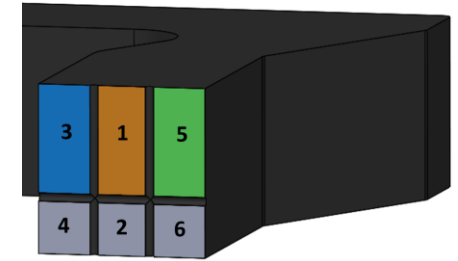

# Flux Distribution Effect on the Ring Core FR78 Impedance – Test II

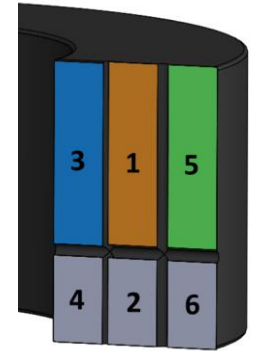

Impedance and phase frequency characteristic.

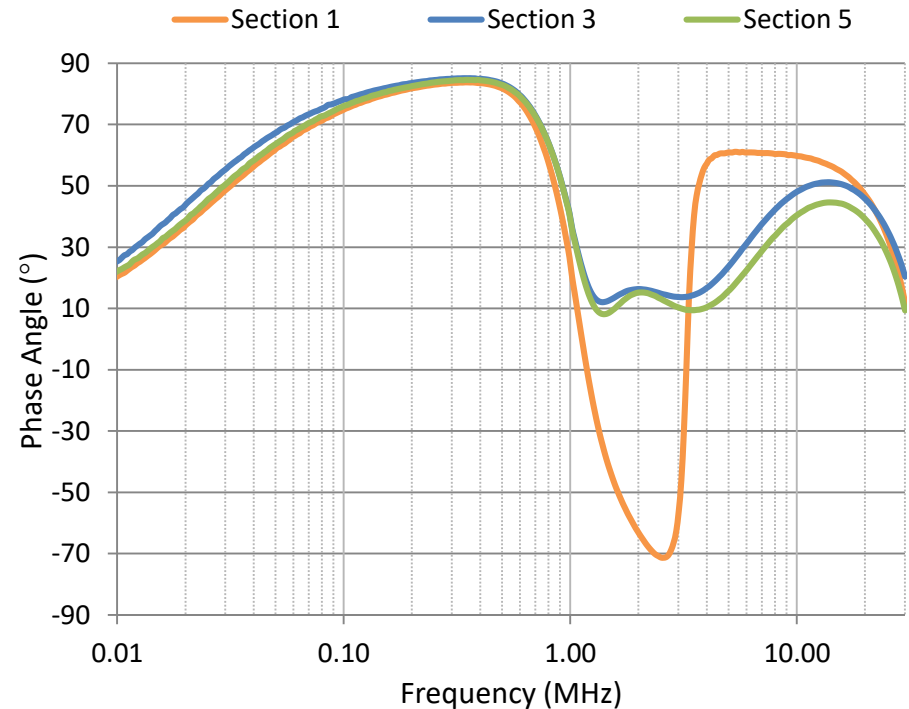
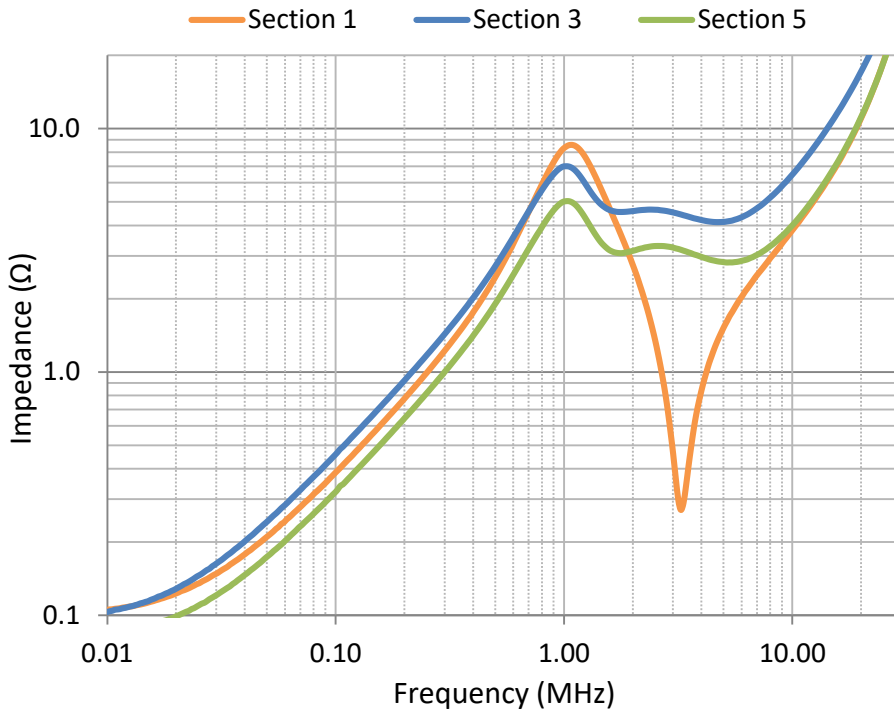

# Summary



- Magnetic material selection is a key for successful EMI filter design and enables to achieve desired attenuation characteristic
- Core size has strong effect on filter frequency characteristic
- Ferrite material is a subject of core skin effect that results in frequency depended magnetic flux non-uniform distribution
- Core material conductivity and permeability influence the skin depth
- Non-uniform flux distribution has an effect on impedance and phase characteristic of each core segment
- FEA modeling is in line with experimental results

# Acknowledgement



- > Ferroxcube Polska Eastern Europe
  - > R&D support and open discussion
  - > Support with samples for research, short delivery times and involvement



- > Fair-Rite Products Corp.
  - > Machining of the frame core
  - > Precise drilling
  - > Samples for research were provided under the sponsorship of PSMA



- > PSMA
  - > Especially Edward Herbert for his enthusiasm and support and valuable discussion on magnetics
  - > PSMA Comitee for support and financial participation in the research



- Mathematical model development based on evaluation of various size
  - Ring cores
  - Frame cores
- Simulation model improvement for better accuracy at higher frequency
  - Permittivity vs. frequency
- Do this research can be applied directly to the design rules? How presented approach contributes to standardized test for magnetic material properties provided by magnetic core manufacturers?

#### REFERENCES:

- [1] Glenn R. Skutt, "High-frequency dimensional effects in ferrite-core magnetic devices,"
- [2] Glenn R. Skutt, Fred C. Lee, "Characterization of dimensional effects in ferrite-core magnetic devices," *Power Electronics Specialist Conference, 1996*.
- [3] B.D Cullity, C.D. Graham, "Introduction to magnetic materials," *John Wiley and Sons, 2009*.
- [4] Frank G. Brockman, P.H. Dowling, Walter G. Steneck, "Dimensional effects resulting from a high dielectric constant found in a ferromagnetic ferrite," *Physical Review 77, January 1950*.

# Demonstrator



- Results for various materials
- Test system
- Tested samples

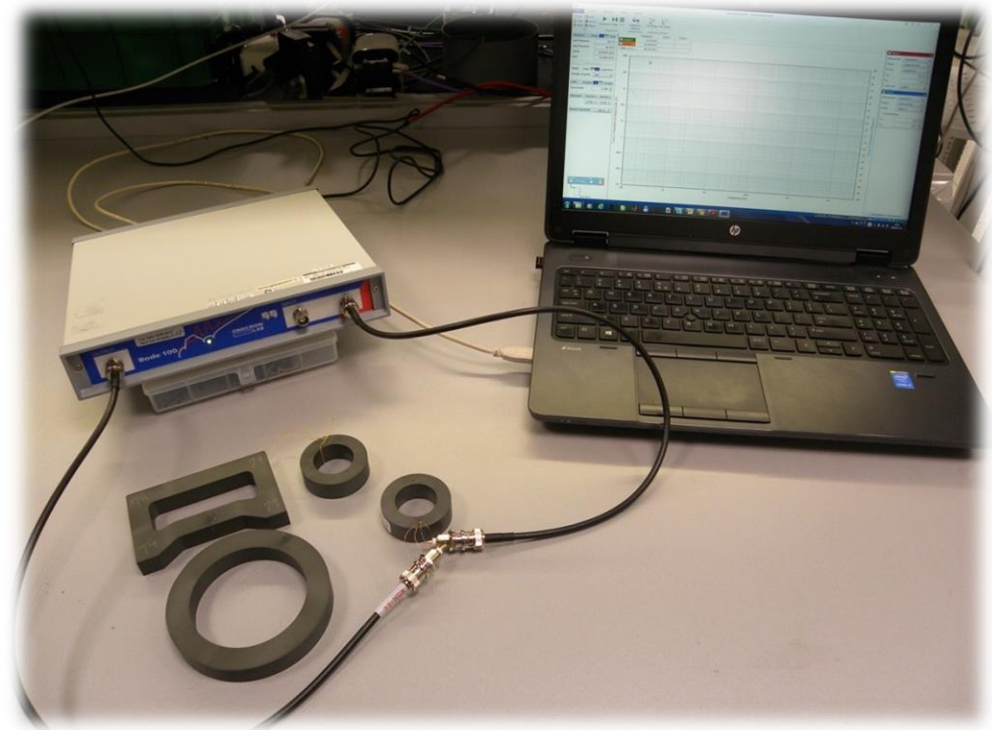

ENERGY  
THAT  
CHANGES



SOCIAL MEDIA  
[www.SMA.de/Newsroom](http://www.SMA.de/Newsroom)

