

Electromagnetic wave shielding effect measurement method using loop antenna

Kosuke Yuasa

Daido Steel Co.,Ltd.

2025 Power Magnetics at High Frequency Workshop
March 15th,2025

- 1.What is Electromagnetic noise ?
- 2.CISPR 25 standard
- 3.What is EMC ?
- 4.Shielding effect measuring method
- 5.Leaking magnetic field
- 6.Theoretical validity
- 7.Introduction of Soft magnetic foil “STARPAS”

What is Electromagnetic noise ?

◆ What is Electromagnetic noise ?

Electromagnetic noise : Unwanted electrical components that interfere with wanted signals and power

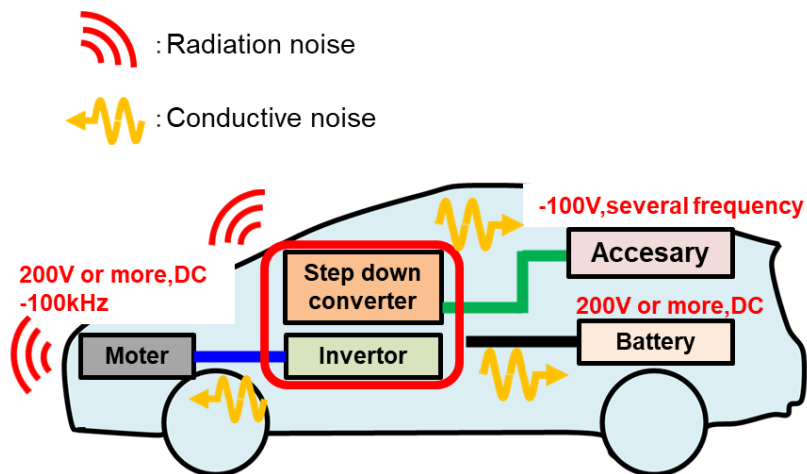

In-vehicle main noise sources

• Switching action of semiconductors in power converters

Noise Type	Noise Form	Propagation Path
Conductive noise	Current, Voltage	Wire Harness Car Body
Radiated noise	Electromagnetic wave	Space

◆ Electromagnetic noise frequency range

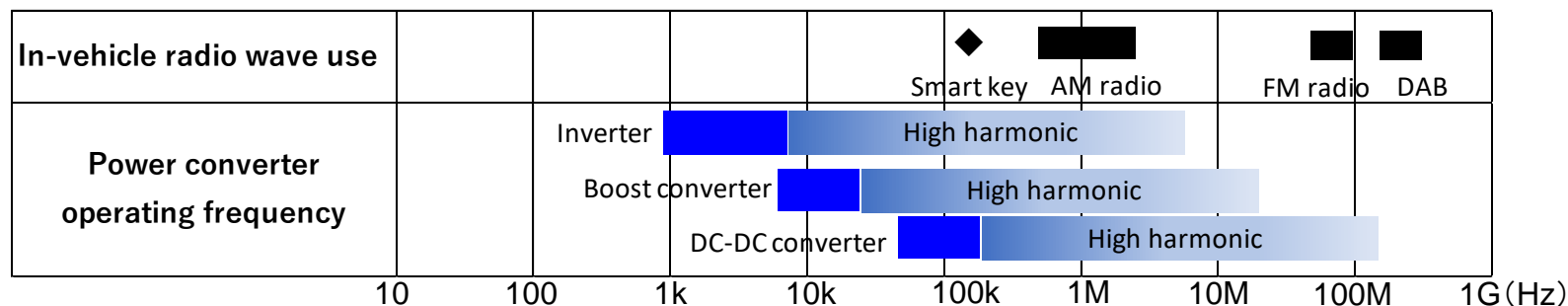

CISPR 25 standard

- Noise problems are becoming more complex and powerful due to the electrification of automobiles.
- Accordingly, CISPR 25 are also responding to wider frequencies and higher power.

CISPR25

Vehicles, boats and internal combustion engines – Radio disturbance characteristics – Limits and methods of measurement for the protection of on-board receivers

Noise Type	Mesurement	Frequency	
Conductive	Voltage	0.15-108MHz	
	Current probe	0.15-245MHz	
Radiated	ALSE	Rod antenna	0.15-30MHz
		Biconical	30-300MHz
		Log-periodic	300MHz-1GHz
		Horn	1-5.925GHz

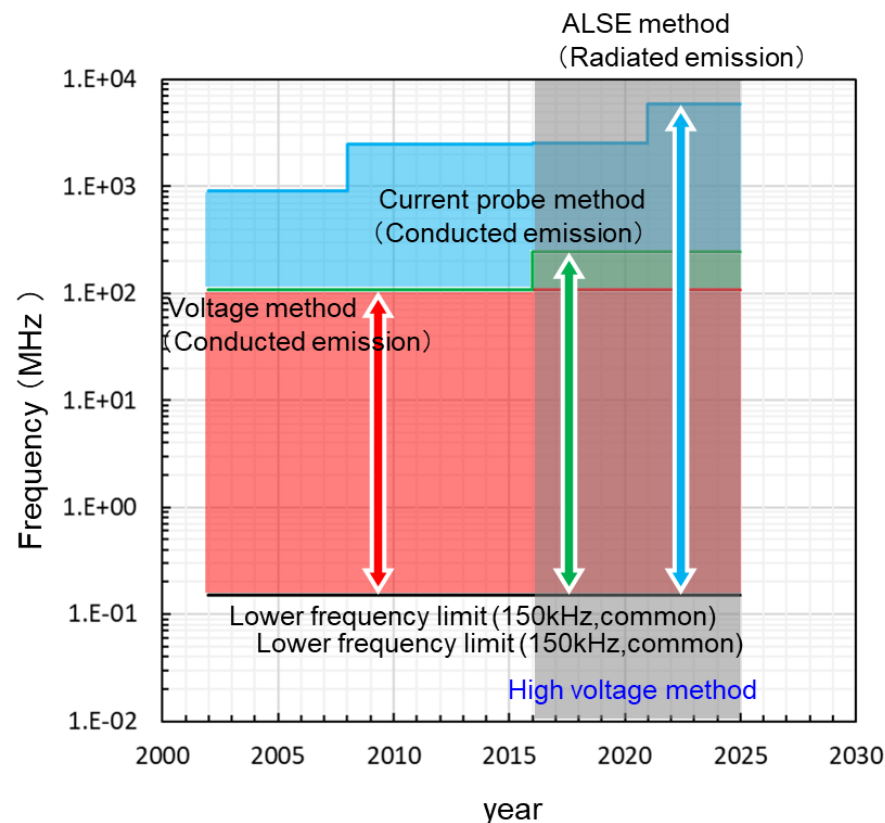
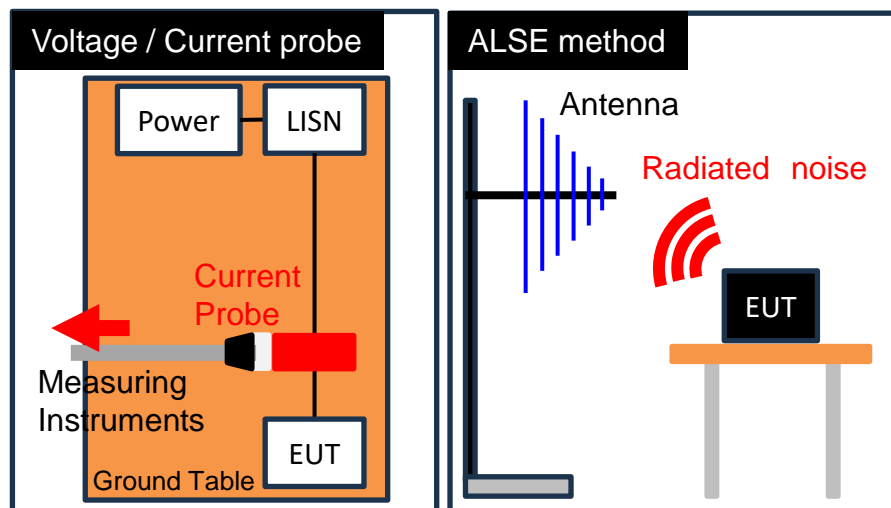

What is EMC ?

- EMC measures are a solution to electromagnetic noise problems.
- **In order to bridge the gap between materials and component performance**, this article presents examples of **shielding evaluation methods**.

EMC (= Electromagnetic Compatibility) Countermeasures : combination of EMI and EMS measures

EMI : Preventing electromagnetic noise from electronic devices

EMS : Prevents the effects of electromagnetic noise from surrounding electronic devices

Conductive noise

→ Blocks noise

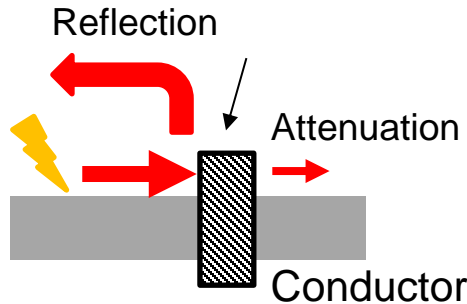

Radiated noise

→ Surrounding the noise source

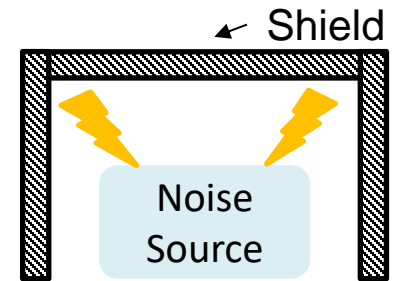

The arrow indicates the flow of noise.

◆ Issues with EMC measures

There is a gap between the performance of materials, parts, and products, making it difficult to implement EMC measures at the design stage.

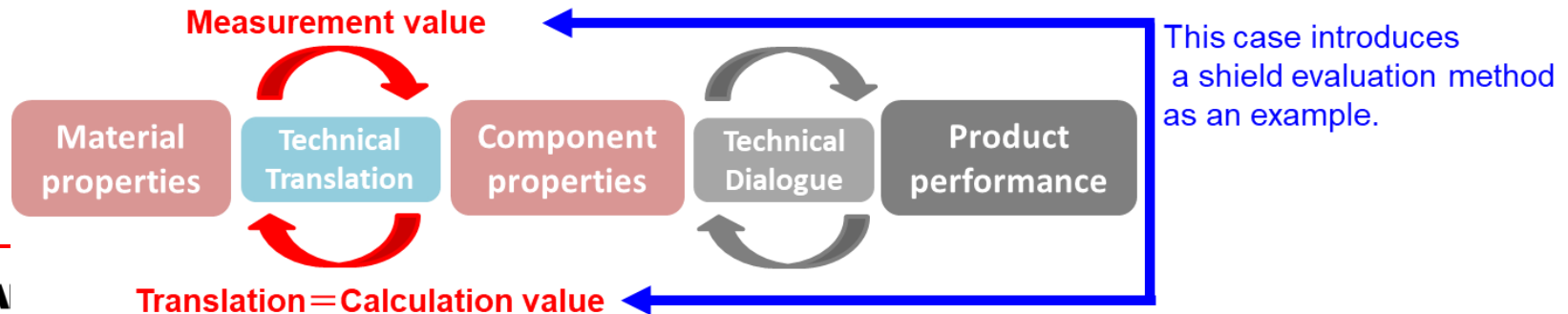

Shielding effect measuring method

- MIL-STD-285 specifies the method for measuring the shield effect of flat shields
- In this study, we will create a shield effect measurement device that takes into account the leakage magnetic field from the sample end.

◆ Method for measuring the shield effect of flat shields

- Standard : MIL-STD-285
- Measure Target : Shielding enclosure

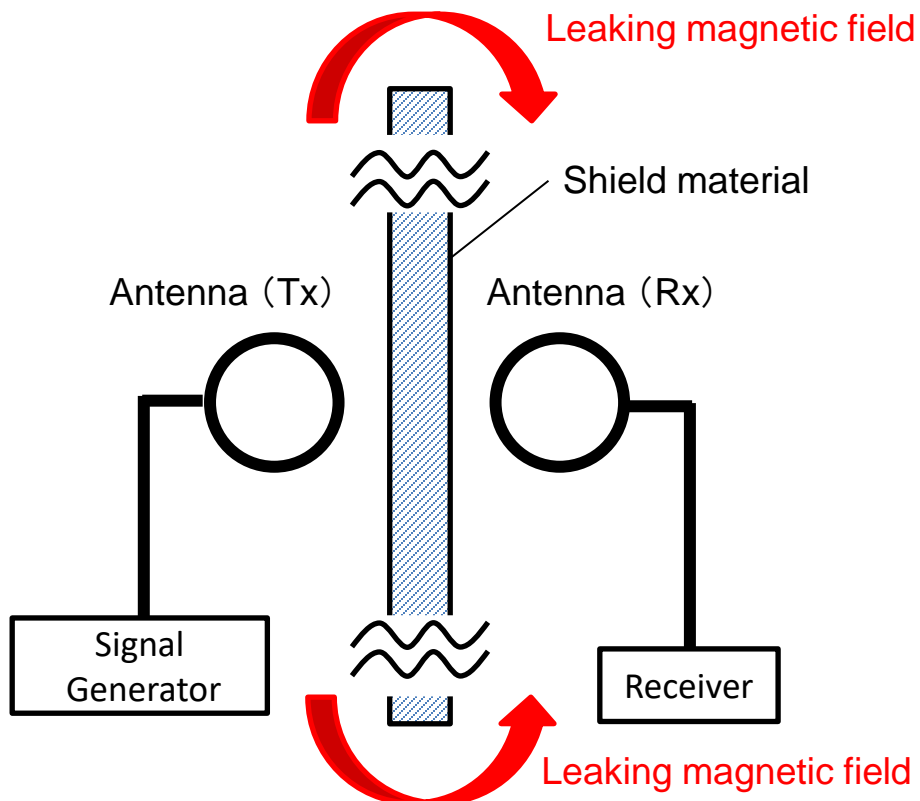

	Detail
Merit	<ul style="list-style-type: none"> • Shield effect can be measured over a wide range of frequencies. ⇒ 10Hz-100MHz • Analysis using theoretical calculation formulas is possible. • The shield effect can be evaluated uniformly regardless of the type of shielding material. ⇒ In this case, Cu foil and soft magnetic foil are measured.
Demerit	<ul style="list-style-type: none"> • A leakage magnetic field occurs from the edge of the sample. • If transmitted electromagnetic wave is less than Leaking magnetic field, correct measurement results cannot be obtained. ⇒ The leakage magnetic field from edge must be taken into account by electromagnetic field analysis.

Shielding effect measuring method

◆ Measurement principle

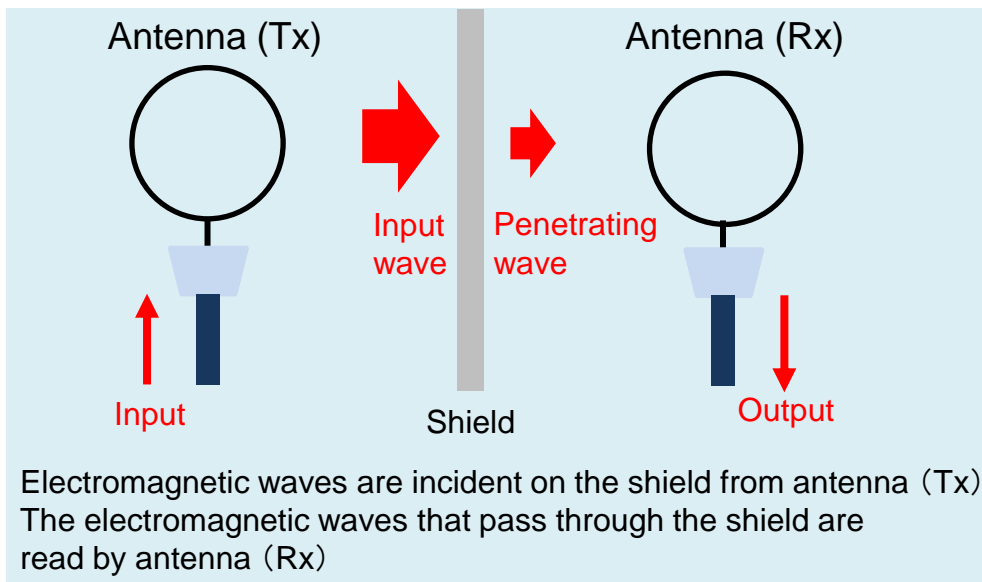

◆ Device configuration

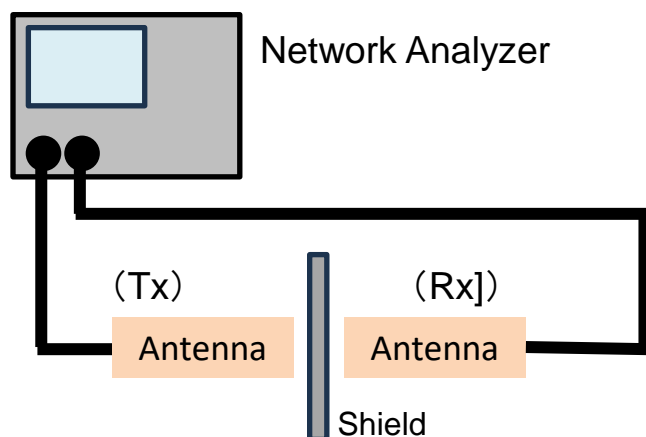

◆ Measuring device appearance photo

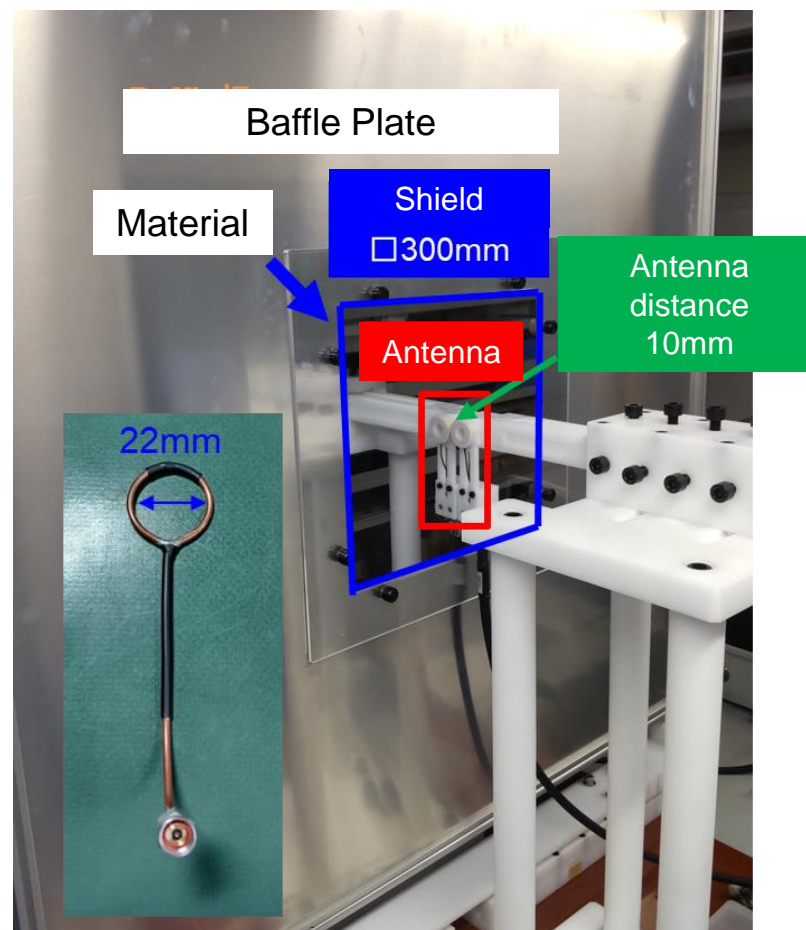

Shielding effect measuring method

◆ Measure Condition

Input Power : 10dBm
 Frequency Range : 10Hz-100MHz
 IFBW : 10Hz
 Measurement Data : S parameter (S_{11}, S_{21})
 Data number : 701 points

◆ Antenna Placement

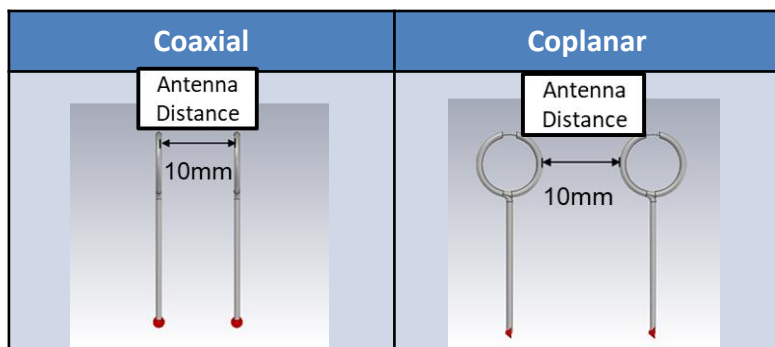

◆ Antenna and Amplifier

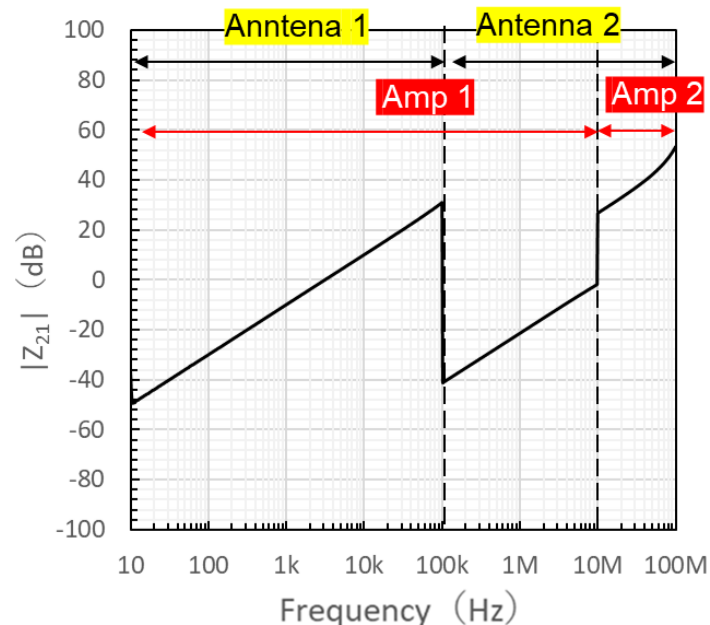

◆ Measurement data conversion

Measurement data



Convert to Z parameters



Z parameter difference

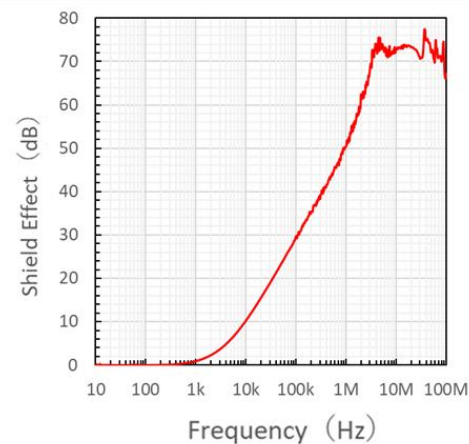
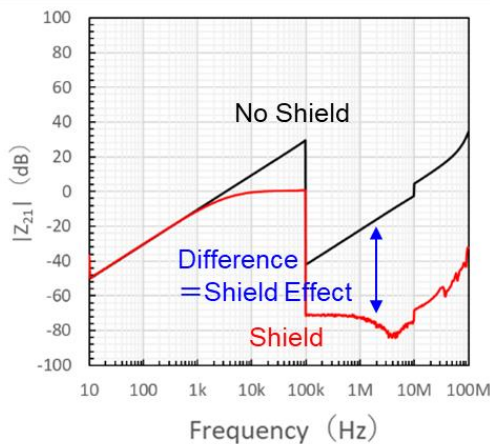
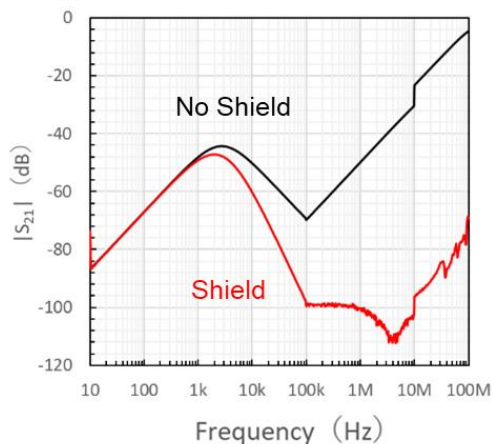

Leaking magnetic field : Analysis conditions

Coplanar

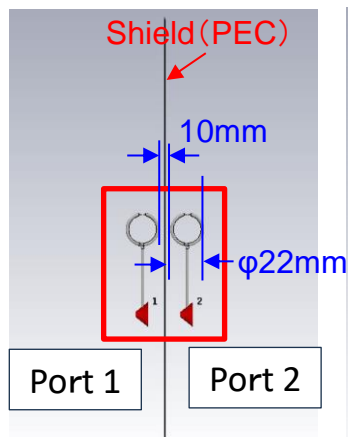

Coaxial

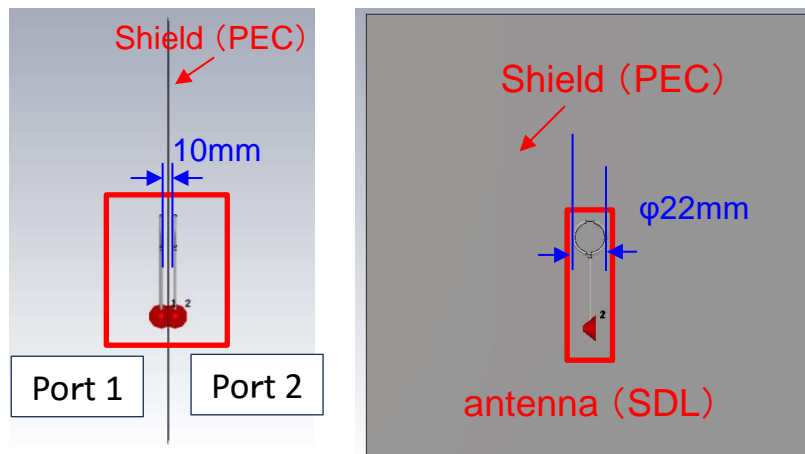

◆ Analysis target and analysis conditions

- Analysis method: Finite element method Analysis
- software: CST-STUDIO HF

【antenna】

- Antenna Type : Shielded Loop antenna (SDL)
- antenna diameter : $\Phi 22\text{mm}$
- Placement : Coplanar, Coaxial
- antenna distance : 10mm

【Shield】

- Shield Material : PEC
- Shield Shape : $\square 300\text{mm} \times t 0.1\text{mm}$

【Analysis Condition】

- Frequency : 10Hz-100MHz
- Mesh : Tetrahedral automatic mesh
- Mesh Number : 200,000 to 300,000
- Boundary Conditions : OPEN

Leaking magnetic field : Electromagnetic Field Analysis

- The results of the electromagnetic field analysis show that the antennas are coupled together by the leakage magnetic field from the shield end.

Coplanar

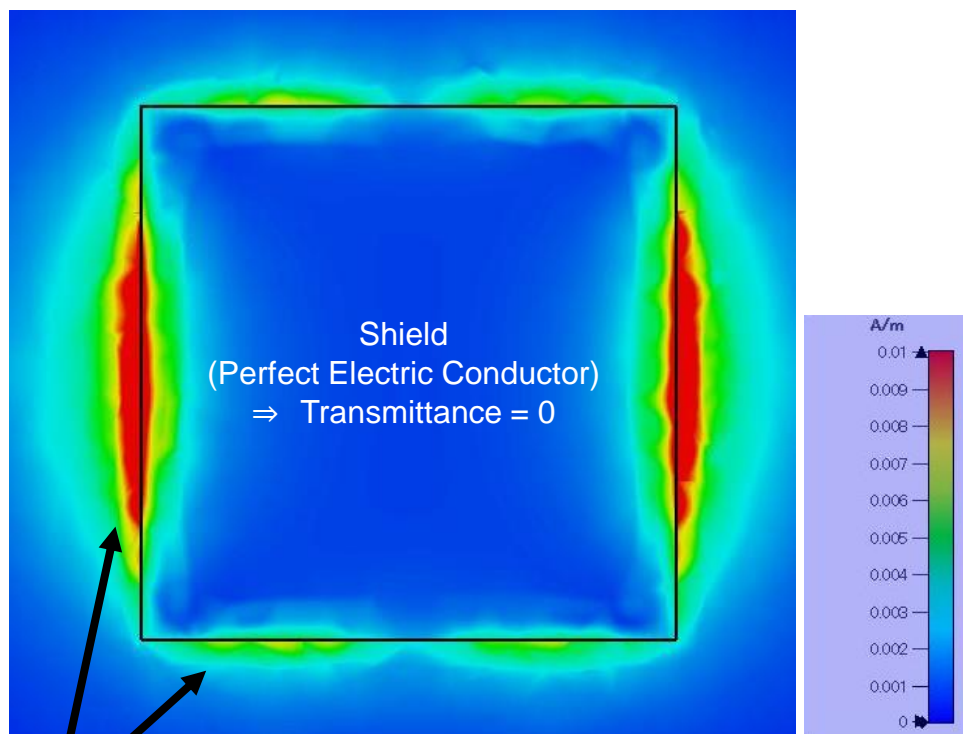

Leaking magnetic field

Calculation Result

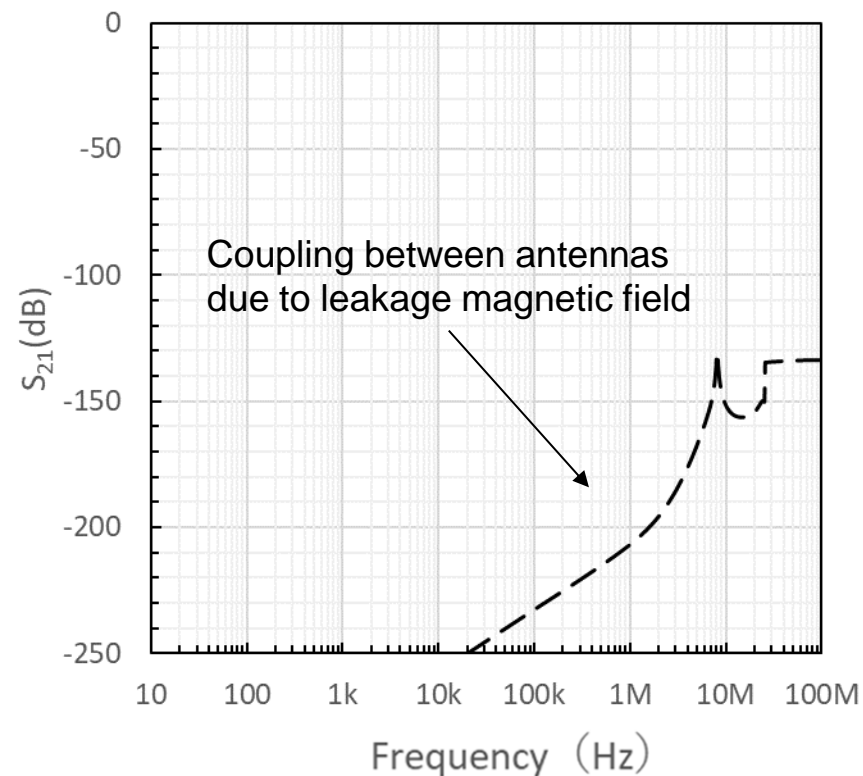

Leaking magnetic field : Comparison with measured value

- The leakage magnetic field obtained from the electromagnetic field analysis is used to determine the area where the shield effect can be measured.

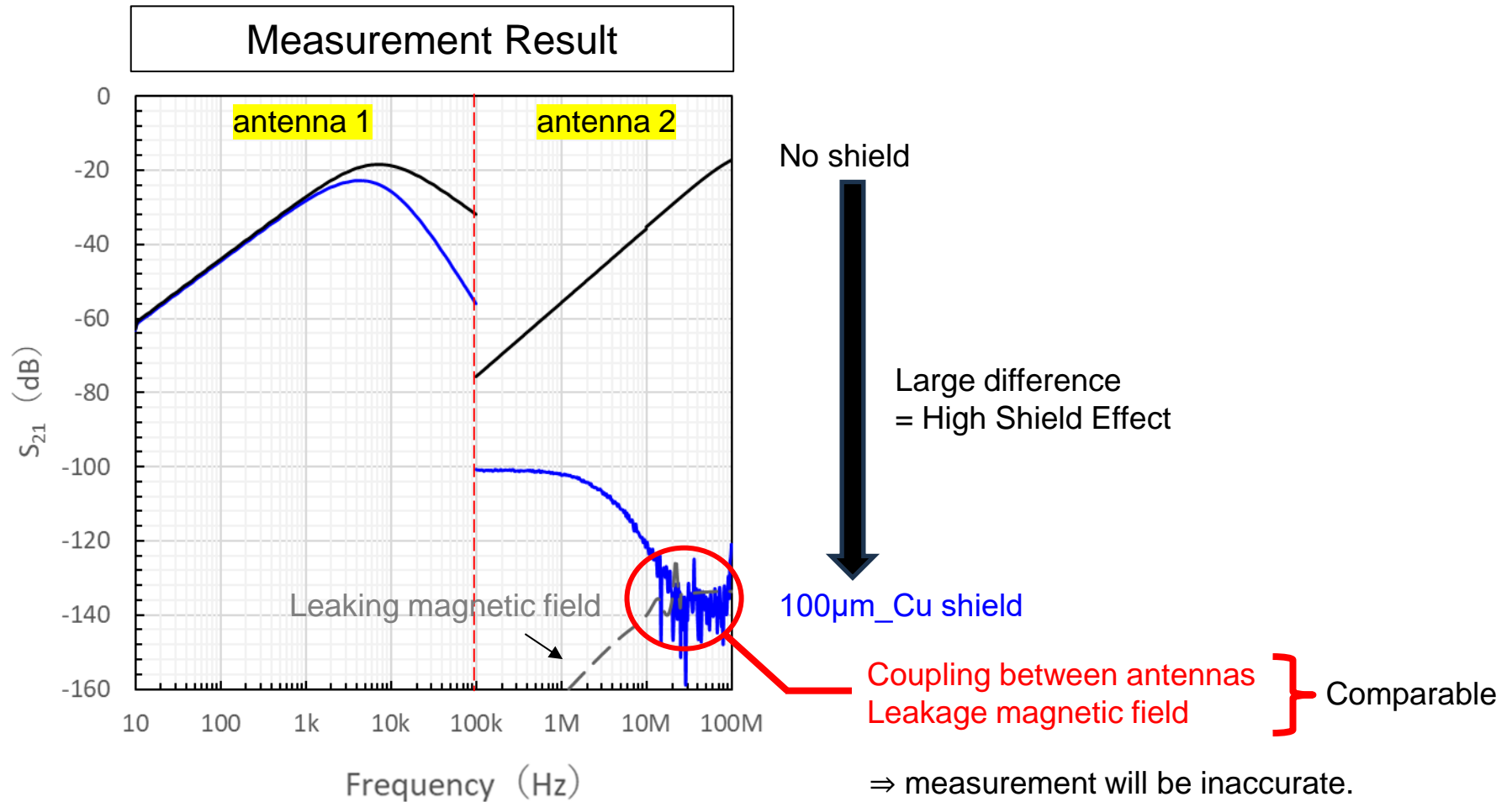

Theoretical Validity : Theoretical calculation of shield effect

- The shield effect is theoretically calculated from the material properties, measurement conditions, and equipment configuration..

Shielding material properties

- Relative Permeability
- Electrical Conductivity
- Shield Thickness

Measurement conditions

- Frequency : 10Hz-100MHz

Device configuration

- antenna diameter : $\Phi 22\text{mm}$
- antenna distance : 10mm

Calculation program

Shield Effect

- ① Splitting the antenna (Tx) into a magnetic dipole sources
- ② Calculate the total magnetic flux Φ interlinked with antenna (Rx)
- ③ Calculate the mutual inductance between antennas from the flux linkage
- ④ The mutual inductance before and after the shield is installed is calculated, and the shielding effectiveness is calculated from the ratio.

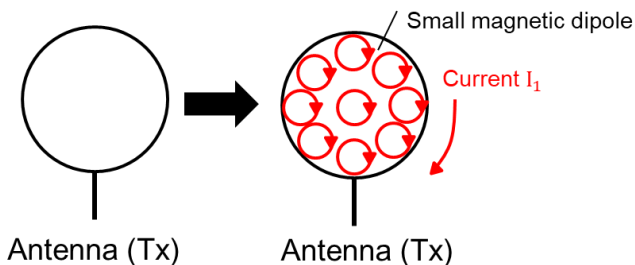
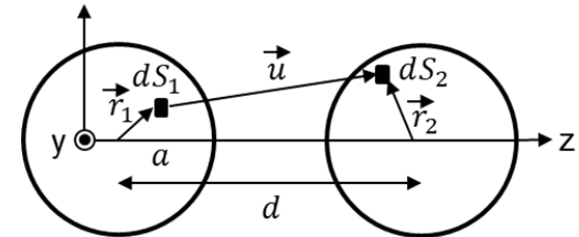

$$\Phi = \iint_{dS_2 \subset S_2} \iint_{dS_1 \subset S_1} \mu_0 I_1 dS_1 b_{yy}(\vec{u}) dS_2$$

$$L_{21} = \frac{\Phi}{I_1} = \mu_0 \iiint_{|\vec{r}_1| \leq a, |\vec{r}_2| \leq a} b_{yy}(\vec{u}) d\vec{r}_1 d\vec{r}_2$$

(Reference: IEEE Trans. EMC, vol. 34, no. 3, pp. 284–291, Aug. 1992)

Theoretical Validity : Comparison of measured and calculated values

- The measured and calculated shield effect of Cu foil agree within 3 dB.
- As a result, the theoretical validity of the new shield effect measurement method was confirmed.

Table Sample List

Shielding material	Sample shape
Cu	□ 300mm × t 0.010mm
	□ 300mm × t 0.020mm
	□ 300mm × t 0.030mm
	□ 300mm × t 0.050mm
	□ 300mm × t 0.100mm

Table Calculation parameter List

Parameter	Value
Relative Permeability	1
Electrical Conductivity (S/m)	5.9×10^7
Shield Thickness (μm)	10,20,30,50,100

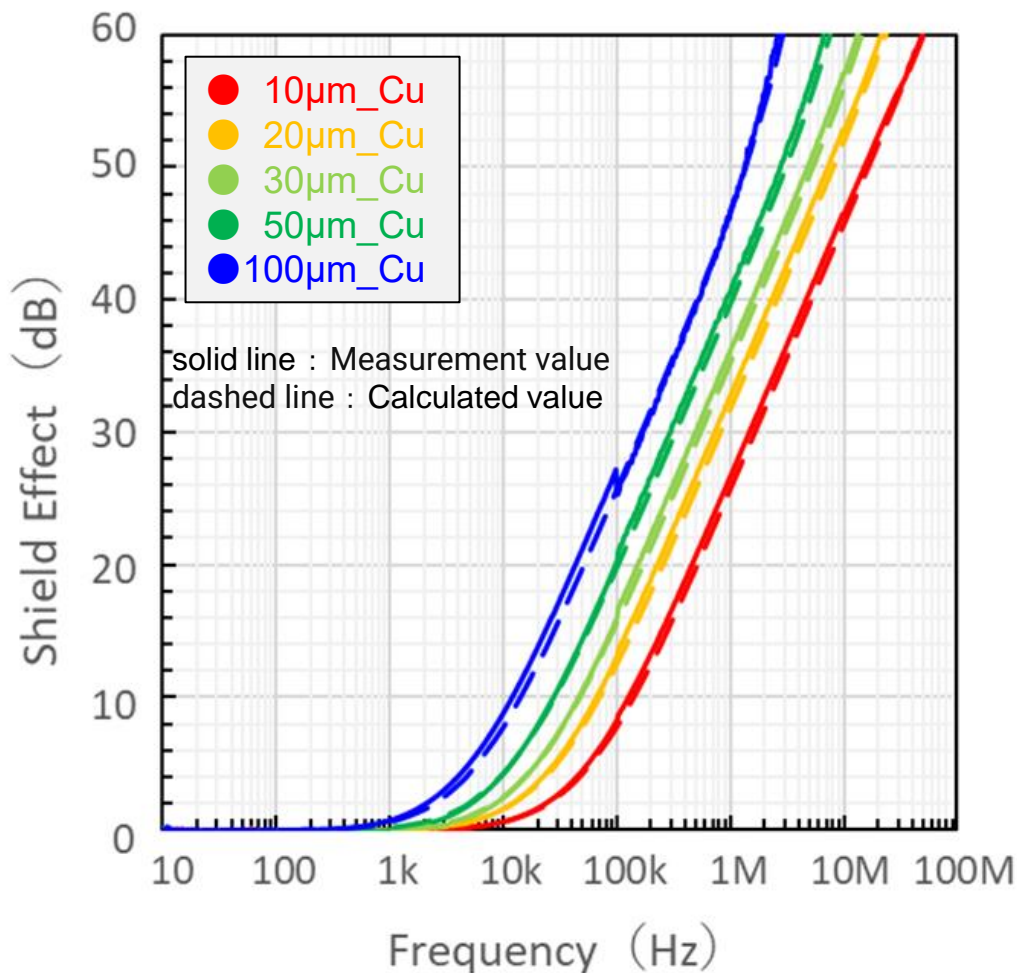

Introduction of Soft magnetic foil “STARPAS”

- Extremely thin permalloy foil (10-50 μ m) with excellent workability and flexibility.
- Excellent shield effect in the kHz to MHz range

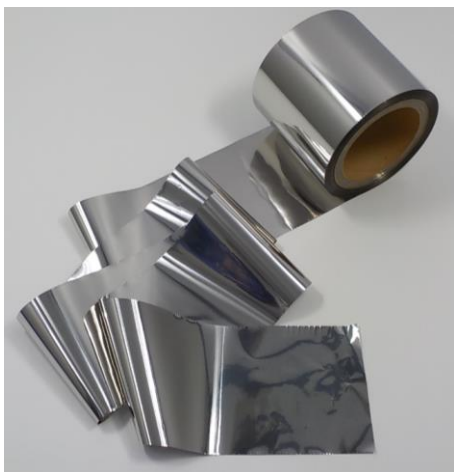

Appearance of STARPAS-30PC2S

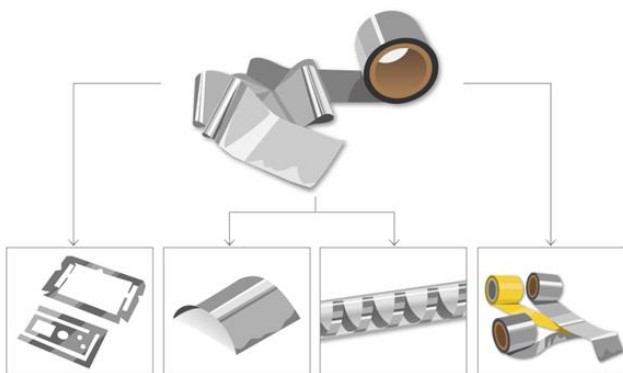

Excellent workability and flexibility

For high sensitivity (Applicable to signal system shields less than a few 10 A/m)

Product	Material	Thickness	MOQ		Width	Max. length	Frequency
			Length	Weight			
STARPAS®-10PC2S	MEN®PC-2S	10 μ m	100m	0.9kg	100mm	1100m or less	50kHz or more
STARPAS®-20PC2S		20 μ m		1.8kg		1100m or less	
STARPAS®-30PC2S		30 μ m		2.7kg		1900m or less	1150kHz or less
STARPAS®-50PC2S		50 μ m		4.5kg		1900m or less	

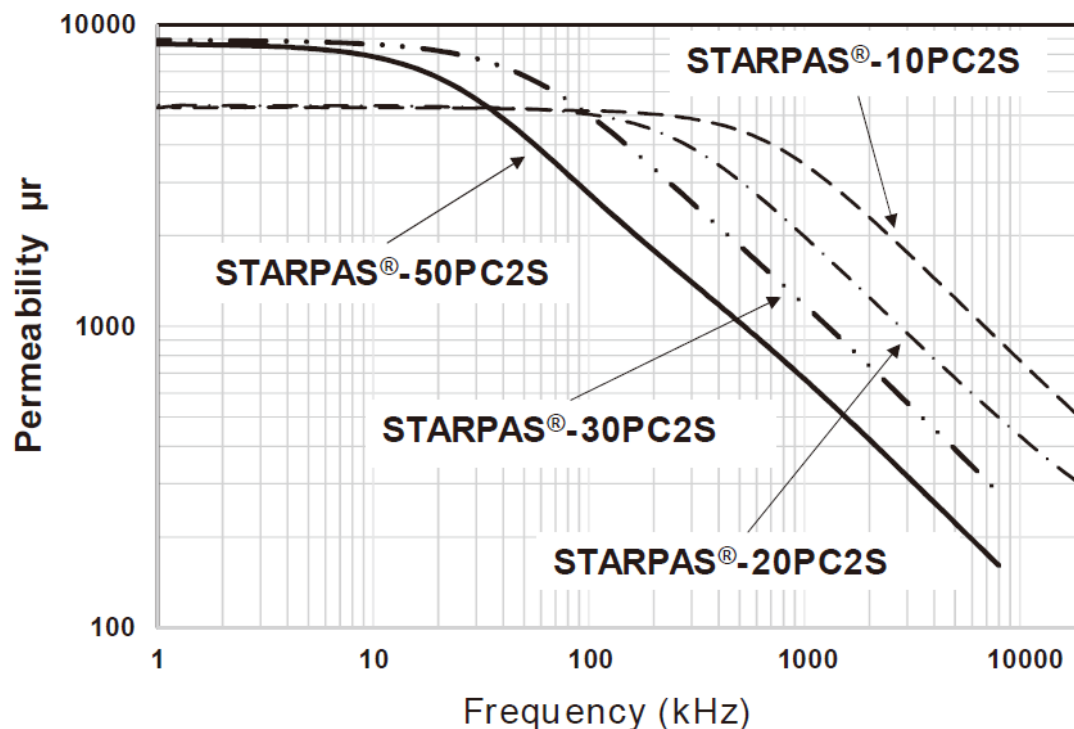

Introduction of Soft magnetic foil “STARPAS”

- STARPAS foil exhibits shield effects even in the low frequency range. ($\sim 100\text{kHz}$)
- Compared to Cu foil of the same thickness, the shield effect of STARPAS is superior in all frequency ranges.

